

DOCUMENT RESUME

ED 381 387

SE 056 193

AUTHOR Bottrill, Pauline
 TITLE Designing and Learning in the Elementary School.
 INSTITUTION International Technology Education Association, Reston, VA.
 REPORT NO ISBN-0-887101-00-4
 PUB DATE Mar 95
 NOTE 59p.; Photographs may not reproduce well.
 AVAILABLE FROM International Technology Education Association, 1914 Association Dr., Reston, VA 22091-1502.
 PUB TYPE Reports - Descriptive (141)

EDRS PRICE MF01/PC03 Plus Postage.
 DESCRIPTORS *Design; *Educational Theories; Elementary Education; *Elementary School Curriculum; *Evaluation Methods; *Experiential Learning; Learning Activities; Science Curriculum; Science Education; *Teaching Methods; Technology Education

ABSTRACT

The main objective of this publication is to raise awareness of the capacity of elementary students to learn using a process termed designing activity. The text is divided into nine chapters. Chapter 1 describes the principles of designing activity. The difference between design activity and design educational activity is discussed in Chapter 2. Chapter 3 outlines some of the methods of modeling and includes the role of drawing and the use of construction kits. Chapter 4 discusses some of the "designerly" thought processes which occurred when students aged 5-6 participated in activity learning related to the topic of farms. The principles and aims of assessing designing activity are outlined in Chapter 6 along with some suggestions for evaluating and assessing students' work. The close relationship among science, technology, and designing process activities in elementary schools is discussed in Chapter 7 in relation to the development of the conceptual theme of change. The role of the teacher in creating a learning environment where designing situations are contrived is discussed in Chapter 8. Chapter 9 looks at some examples of the way design and technological activity has been managed across a class and the whole school. Contains 21 references. (LZ)

 * Reproductions supplied by EDRS are the best that can be made *
 * from the original document. *

DESIGNING AND LEARNING

In The Elementary School

"PERMISSION TO REPRODUCE THIS
MATERIAL HAS BEEN GRANTED BY

JUDY
MILLER

TO THE EDUCATIONAL RESOURCES
INFORMATION CENTER (ERIC)."

U.S. DEPARTMENT OF EDUCATION
Office of Educational Research and Improvement
EDUCATIONAL RESOURCES INFORMATION
CENTER (ERIC)

- This document has been reproduced as received from the person or organization originating it.
- Minor changes have been made to improve reproduction quality.

• Points of view or opinions stated in this document do not necessarily represent official OERI position or policy



BEST COPY AVAILABLE

DESIGNING AND LEARNING

In The Elementary School

Pauline Bottrill

This monograph was made possible by a grant from
the National Endowment for the Arts.

Published by International Technology
Education Association

ISBN: 1-887101-00-4

DESIGNING AND LEARNING IN THE ELEMENTARY SCHOOL

Theory and Practice of developing design education activity at elementary level.

INTRODUCTION	5
1. CHILDREN DESIGNING	7
2. THE ACTIVITY OF DESIGNING: the terminology	13
3. COGNITIVE MODELING: a distinctive capacity of the mind	17
4. DESIGNERLY THINKING: designing activity in the context of topic work	21
5. DESIGN EDUCATIONAL ACTIVITY	29
6. ASSESSMENT APPROACHES FOR DESIGNING ACTIVITY	37
7. SCIENCE, TECHNOLOGY AND DESIGN: process learning activity in the context of a theme	40
8. THE ROLE OF THE TEACHER	47
9. MANAGING A DESIGN PROJECT	51
REFERENCES	55
Profile of Author and Editorial Group	57

This monograph was made possible by a grant to the International Technology Education Association from:

The National Endowment for the Arts
Design Arts Program
Nancy Hanks Center
1100 Pennsylvania Avenue, N.W.
Washington DC 20506-0001

Published by:

The International Technology Education Association
1914 Association Drive, Reston, VA 22091-1502
Tel: 703-860-2100. Fax: 703-860-0353

Copyright © 1995 Pauline A. Bottrill

All rights reserved. No part of this publication may be reproduced, stored in a retrieval system, or transmitted in any form or by any means, electronic, mechanical, photocopying, recording or otherwise, without permission in writing from the copyright holder or ITEA.

ISBN: 1-887101-00-4

Printed by: Corporate Press, Landover MD.

Photography

Except where otherwise stated, all photographs have been taken by Pauline Bottrill.

Acknowledgements: A contribution towards the production of this monograph was provided by LEGO Dacta. The educational division of LEGO Systems Inc.

Equipment and tools supplied to the project by Modern Schools Supplies and Plastruct are gratefully acknowledged.

To the teachers and students of Fairfax County, Virginia who generously participated in the project activity which led to this publication.

LEGO®, DUPLO®, and LEGO DACTA® are registered trademarks of INTERLEGO AG.

LEGO Dacta is the educational division of The LEGO Group.

INTRODUCTION

This publication is about designing activity and its development in the elementary schools. The main objective is to raise awareness of the capacity of students to learn through designing activity. Design activity is not a term that is widely used in general education; nevertheless the mental and physical processes of designing are an important part in children's learning and understanding. Many technology educators already recognize the importance of designing in enhancing learning in technological activity and use designing as a means of directing learning about technology. This publication outlines some of the principles of designing activity and of children's learning. It discusses the major thinking processes involved in designing and describes some ways that designing activity can be incorporated into the elementary curriculum.

The text is prepared primarily for elementary educators. It is directed to curriculum coordinators, school principals and administrators who are influential in making decisions about curricula, especially in the early grades, so that they will appreciate that design and technological awareness should be interwoven into all children's learning. It is for technology educators who are developing programs of study at the elementary level so that they might gain a deeper understanding of the principles of designing. It is for teacher educators, classroom teachers, students who are training to become teachers, and for parents who are interested in the shape of the curriculum of the future.

The curriculum material for the publication was funded by the Design Arts program of the National Endowment for the Arts (NEA) and the International Technology Education Association (ITEA). Through this project these two organizations are working together to support both design and technology education at elementary level. The Design Arts program of the National Endowment for the Arts works on the premise that young people who are educated about the process of designing are more likely to participate in shaping the environment, and seek excellence in the design of buildings, public spaces and products. Design activity in school can enable students to appreciate the human-made world in which they live and work; and through taking action with technology, students can begin to shape their future environment. The International Technology Education Association is committed to introducing technology education from kindergarten through 12th grade and has stated that technology education should be a basic of every student's curriculum.

Several issues need to be addressed before introducing design (and technology education) activity into elementary school. The first consideration is about young children and how they learn about the designed and technological world in which they live. Chapter 1 looks at two children who were behaving in a designerly way (ie. similar to the way designers be-

have) in their play; there were no adults or teachers around to structure, supervise or interfere in their activity. By observing children at play in their natural environment, we can see their emerging design ability.

There is a body of literature in science education which suggests that students come to school with considerable prior knowledge and pre-experience about the physical world which is borne out by this kind of observation. However, the way children learn about the physical world in their natural environment through designerly behavior appears to hold a key to their overall learning and development. So far, little research has been done in this field. Chapter 1 is very important to the whole text as it sets out the principles of designing activity.

Another problem is that the terminology related to design can deter non-professional designers. There is no attempt here to systematically define design and designing. Some complicated terminology, however, has to be used such as 'cognitive modeling', 'imaging', 'modeling' and 'designerly thinking', and these will be discussed in Chapters 2 and 3 in the context of children designing. The difference between design activity and design educational activity is discussed in Chapter 2. Chapter 3 outlines some of the methods of modeling and includes the role of drawing and the use of construction kits.

Chapter 4 discusses some of the designerly thought processes which occurred when students aged 5-6 participated in activity learning related to the topic: farms. The student's response was compared to the account of children at play in Chapter 1. Although the examples focus on kindergarten activity, the model of designerly thinking in topic work is relevant to other elementary grades. An activity which characterizes design education activity is discussed in Chapter 5.

It is possible to draw out criteria for assessing designing activity through students' activities. The principles and aims of assessing designing activity are outlined in Chapter 6 and some suggestions for evaluating and assessing students' work.

In the elementary school, science, technology and designing process activities look very similar. The close relationship between these areas is discussed in Chapter 7 in relation to the development of the conceptual theme: change. Students aged 6-7 explored several learning opportunities based on the theme. All the tasks involved activity based learning but only some of these experiences exemplified designing. Learning through science and technology curricula, however, provides knowledge and understanding which contributes to designerly exploration.

This publication is based on a belief that young children are capable of making designing decisions of their own when they come to school, and can therefore make designed and

technological artifacts, systems and environments. The key issue here is to decide what teaching and learning strategies might be appropriate when students design and are allowed to take responsibility for their own learning. The role of the teacher in creating a learning environment where designing situations are contrived is discussed in Chapter 8. Again one has to return to the issue of children's capability. Educators need to be attuned to how children themselves gain their understanding of design and technology so that they can enhance students' opportunity through the curriculum.

Designing and technological activity works best when there is a program of progression through the elementary school. Chapter 9 looks at some examples of the way design and technological activity has been managed across a class and the whole school.

A major focus of this publication is that children learn before schooling and outside school in natural settings. Each chapter iterates the scenario of children's designerly play observed on a beach. The children were involved in play which appeared to characterize the principles of designing and the processes involved in designing a system. This device has been used so that readers hold an image in their mind of designerly activity which can be compared to designing and learning situations contrived for the classroom. Design education activity may be found or developed across mainstream elementary curriculum.

This publication, however, emphasizes the developmental nature of learning about the designed and technological world. It supports the view that designing is an educational activity in its own right. It is hoped that this monograph will encourage more teachers to foster student's learning through integrating designing activity into technology education and other learning areas.

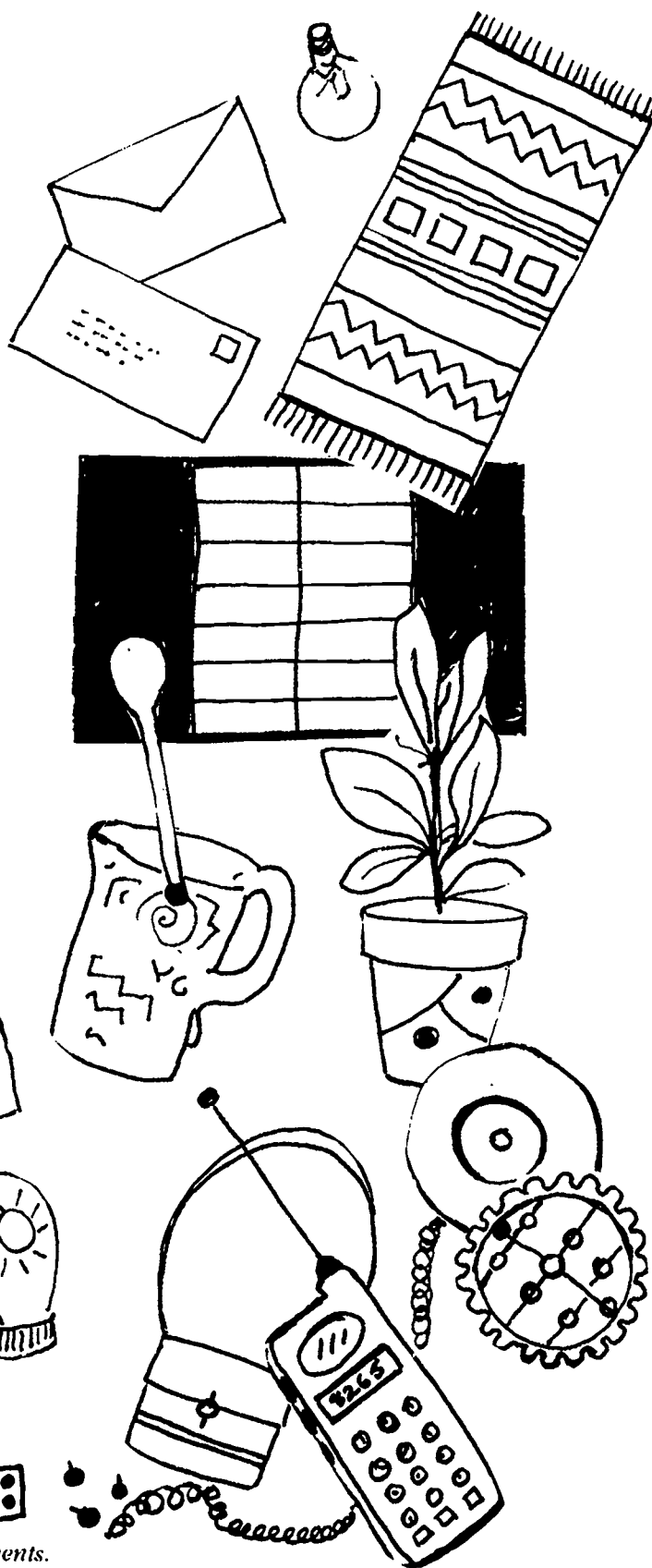

Design in the world around us: artifacts, systems and environments.

1

CHILDREN DESIGNING

► *Children's early development*

Children begin to learn about what people do and about the natural and made world from the time they are born. A body of research evidence was accumulated and described by Bower (1977) which shows that babies and toddlers respond cognitively to their surroundings. A baby's exploration commences with sensory development such as grasping and sucking. Through imitating sounds, movement and other sensory experience, and by physical action such as pulling, tugging, manipulating and arranging phenomena, children learn about their physical environment.

► *The relationship between play and designing*

This interaction with people and the physical world known as play has been recognized by designers such as Baynes (1994) as incorporating many of the characteristics of designing. The question is what kind of activity constitutes 'designing' and what is merely 'play'. Do young children have a capacity to design? Baynes believes that they do and that this ability commences when children are very young. An important element of designing is the presence of both creative thought and action. While there is a considerable body of literature on children's play and its significance to education, it is usually focused on behavioral activity. Rubin, Fein and Vandenberg (1983) and more recently Pellegrini and Boyd (1993) conclude that play seems to be instrumental in children's social and cognitive development.

Play varies in the degree of thought and action present. Play can be solitary or it can be a very social activity involving many people. Social interaction can be important in both play and designing. Even an only child may depend on a parent or care giver to facilitate her / his play activity. Props are often important in play activity.

► *A designing and playing scenario*

Here is a description of a play activity where the children behaved in a designerly way:

The small boy and his companion were absorbed for two hours playing with a home manufactured sailing boat. They may have helped in its construction but that was immaterial to the task. The important task for them was launching and re-launching and perfecting and testing the launch. They were trimming and testing the sails, adjusting and readjusting the rudder. The aim was to achieve a perfect launching, to capture the wind and water, meet the objective and haul the yacht on its rollers back up the sand... and start all over again.

It was absorbing and compelling for both the observer and the children. This activity was undertaken in response to the cultural environment of island living (an island known for its racing yachts, which on this day were racing the boats of a rival island). It involved the exploration of technical knowledge and skill, it demanded organizational thought and action to achieve an aesthetically meaningful goal. There was evidence of a good deal of thinking and learning taking place during this activity. The activity involved knowledge and skills that were unlikely to have been learned from school (the small boy had not reached school age yet but he knew a lot about sailing boats) and there was no teacher or other adult present. A considerable number of designing characteristics were observed. Above all, most people would agree the two boys were 'playing'.

This image of two children playing and designing will be used throughout the text as a focus for understanding design thought and action. In this play situation an analogy has been made between designing and play activity.

This scenario raises several questions: 1) On what grounds can one say that the boys were designing? 2) Is there a relationship between designerly activity and young children learning? 3) What is the purpose of doing design activity in school when children design happily through play? These three questions are discussed:

The principles of designerly activity

► *Design products, systems and environments*

Are the boys designing? Many observers might suggest that design activity would have to involve the planning and making of the model sailing boat and attribute a product to be the result of designing activity. Thinking about and making a product is indeed a designing activity. This example has been singled out because the boys are designing a system that will work for them, an important aspect of thought and action which is less widely understood.

Another kind of designing activity which is not discussed here is designing an environment. If the boys had reshaped the beach, by creating sand castles and making channels of sea flow in a different direction, they could have been said to be designing an environment. All designing activity involves both mental and physical actions. It is not possible to see the private thoughts of human beings, it is only possible to see their course of action through for example, bodily kinesthetic action, and through the means they choose to convey their ideas, problems and solutions.

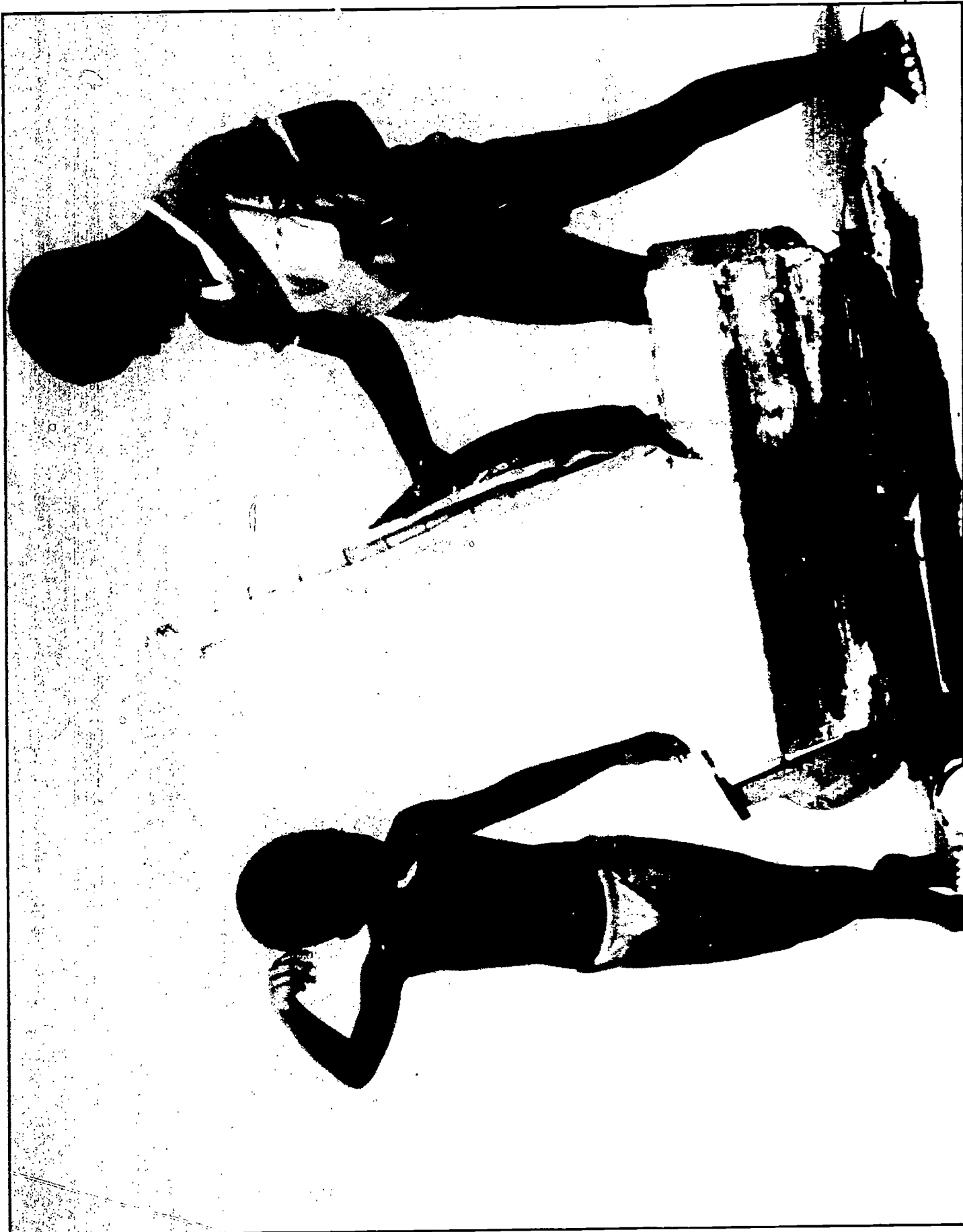

BEST COPY AVAILABLE

*In this play situation an analogy has been made between play activity and designing
the boys are constructing and reconstructing ideas with materials in their surroundings*

► *Designerly play and designerly activity*

Play which is described in the text as 'designerly' is play which is analogous to the way professional designers think and behave. Archer (1992) notes that a designers approach is the opposite way round to a scientific or scholarly approach to a task. Designers start with general ideas and then work toward a particular problem or need. Other approaches work from a particular focus and work towards the general. The principles of designerly activity are based on research evidence of what professional designers do when they design. (Archer 1984 and others). The play activity of the boys appeared to correspond to the principles of designerly activity in the context of designing a system which would work.

The main principles of designerly activity are:

- **responding to an identified or perceived need** (to control the performance of a model sailing boat);
- **creating something which did not previously exist or modifying something** (this activity involved modifying a system of launching to achieve a satisfactory solution);
- **communicating thoughts and action using models and codes** (the boys communicated their thoughts and ideas through words and demonstrative action. the boat is a model, but for the children it represented the real thing)
- **attaining an intentional outcome even though it may be ill-defined** (can only be determined in this case by the behavior of the boys which was deliberate and purposeful);
- **following a coherent and structured course of action which is interactive** (the rules of the action were being created by the boys through the course of the action, there was a pattern of trying something out, evaluating it, trying another way-this is the basis of design methodology);
- **taking place over time** (in this case the subjects were involved for two hours of concentrated action. Design processes take place over time);
- **being manifested within a system of values** (two kinds of values were observed: technical quality and aesthetic judgments and skills, the object was to achieve perfection. Other value systems are ethical, political, moral, economic, cultural and social)
- **reaching an outcome was a compromise of the accumulative demands of the activity** (each attempt was subject to the elements of wind, water and density of sand and to human error in adjusting the model);
- **justifying the outcome by the results or justifying the results** (in this case a result is the perfection of a system that works. One would need to ask the boys who were also the clients whether this worked; perhaps they did capture a perfect solution, then again when they try another day the tides and wind will have changed).

On these grounds one can conclude that this activity represents a characterization of a designerly activity in the children's social environment. The setting will be varied: urban and inner urban, home or in the neighborhood, with props or nothing at all. Each circumstance for designing is unique to the individual child. The main principles that are listed above can be tested against children's individual and group activity both outside and inside school. These principles of designing will be discussed again in Chapters 5 and 7.

* it might be as well to mention here that drawings and diagrams which represent ideas are a form of communication which will be discussed in Chapter 3. Drawings and diagrams are models of design but are not prerequisites of designing activity which some methodologies suggest.

The second question depends on whether one accepts that some play activity is analogous with designing:

Is there a relationship between designerly activity and young children learning?

What was evident through this observation was that the children had already acquired knowledge about sailing boats and about the force of water and wind. They could participate in this game from a fount of prior knowledge; they had seen people manipulate boats; they had experimented by themselves; trying out their skills many times before. They were applying this knowledge and skill to their task. Some of this knowledge could be classified as scientific knowledge involving the understanding of materials, energy, forces and construction with technical 'know how' of applying this knowledge.

As they experimented they would build further knowledge through trial and error, solving problems as they arose through continual thought and action. Schon and Wiggins (1992) see design as a reflective conversation with materials. The designer sees what might be done, acts in relation to what has been seen and draws upon this knowledge. They suggest that designing is an educational activity in its own right. The boys seemed to be engaging in a spontaneous inquiry through playing with the boat and ultimately learning from their efforts.

This activity of the children, based on already absorbed information also involved the creating of new ideas inside the head through a process known as 'imaging' and 'modeling'. This is the core of designerly thinking. The mental activity takes place, but because it is invisible to the human eye it is difficult to measure. The phenomena of imaging and modeling will be discussed in more detail in Chapters 2 & 3.

Learning about and applying technology is one part of learning about and through designing. the other part concerns people, their society and culture. The boys are learning about their special environment. they have been watching people around them handle all kinds of craft, and this activity has

stimulated curiosity and inquiry. In one sense they are imitating the actions of others and learning about what they do but at another level they are thinking about what if.....? and using their imagination and intuition to create a new reality.

This island culture is based on the traditions of the sea with its history embedded in the physical surroundings. The people who live there and their social activities inform the actions of the children. Apart from learning through observation, exploring materials, and imitating the social activities, the boys are constructing and reconstructing ideas through action on the environment. This is acknowledged as an important learning device by Piaget (Flavell 1963) and more recent educators (Kamii and DeVries 1983, Chaille and Brittain 1991).

► **Constructivism**

As a conceptual learning theory, constructivism has become a bit of a catchword in recent early childhood literature, especially among science educators. Howe (1993) points out that constructivist teaching models are often vaguely defined. It is widely accepted that children learn through constructing their own knowledge and this experience seems to be very important in the development of designerly thinking. However constructivist teaching models developed by science educators are not always conducive to developing designerly thinking skills. This may be because the aim of science is focused towards explaining the world while in designing the need is to deconstruct and use the knowledge creatively.

A constructivist approach to teaching involves creating a learning environment where students are actively involved in building knowledge about their physical world through practical activities. In the context of the model boat these are the kind of focus questions that children might be encouraged to ask: How can I make it move through the water (across the sand)? How can I change the sails to catch the wind? How does the boat fit onto the rollers? The children are encouraged to build their own theory. However this teaching models fall short in developing for example: intentional, productive, inventive, expedient and integrative thought and action. Designerly activity also requires the development of meta cognitive processes. The learner has to use 'be constructed knowledge with other knowledge and skills in designing activity.

Other issues related to science and technology will be discussed in Chapter 7. What is important to note here is that designing activity develops children's ability to learn not only about what exists but how to apply knowledge and to think about what might be done in future time. The content of learning is not just concerned with the status quo but is actively propelled towards the future, an important point of technology education. People who design by using their senses and by imitating, representing and constructing knowl-

edge also seem to be learning. This active participation in designerly thinking may be a driving force in generating future knowledge and information.

The example of boys activity on the beach suggests that children can design on their own through self initiated play activity. This leaves the question: do schools have a part to play in developing design activity?

What is the purpose of doing design activity in school?

► ***Designing as a fundamental capacity***

All school activities are contrived in some way towards developing life skills. Children often start to read outside school if exposed to written material and to engage in simple number transactions. Language and number are unquestionably basic areas of knowledge and skill. There is no argument that these are fundamental requirements of teaching and learning in a school setting. They are not left to the serendipity of the natural setting of children's play. The kind of actions, mental and physical that have been described above are equally vital to children's development and should also be accommodated in school. This fundamental area of knowledge and understanding is described in the text as 'designerly' thinking (see Chapters 2 and 4 for further explanation). It is a key to gaining a more comprehensive understanding of the physical world we live in, including the cultural, social and economic aspects of human life. A better understanding of designing helps to make sense of other universal curriculum basics such as science, art, social studies, and technology education.

► ***Contriving designing situations in school***

Left to themselves the boys play may have become stale and repetitive. There comes a point where children need to be challenged to take the activity beyond the knowledge and understanding which has been reached. In a school situation the teacher's job would involve initiating the kinds of thinking whereby children can engage in design educational activity (some strategies will be discussed in the Chapters 4 and 8) beyond where they would be taken in everyday play. This should commence in the early years building out of the early explorations that children have made in their social world.

► ***Students prior knowledge and experience***

There has been an increased emphasis in the past decade by educational psychologists on seeing children as social beings rather than individuals (Eruner and Haste 1987). Children also come to school with a considerable amount of knowledge and prior concepts about how the world fits (Osborne and Freyberg, 1985 and Driver et al. 1993). It is no longer accept-

able for teachers to consider students as empty vessels waiting to be filled up with knowledge and skills.

► *Innate and gender social conditions*

In the natural environment there are both innate and social gender conditions at play in determining activities. Would either of the boys have demonstrated such equity if their play partner was a girl? How would girls have played with the sailing boat? Opie (1994) visited a primary school playground weekly over a two year period and made an ethnographical study of the children playing during the recess. She observed innate differences between the sexes, which may account for the separation of boys' groups from girls" (with the exception of one or two individuals). Boys, she reports, were "more egotistical, enterprising, competitive, aggressive, and daring than the girls. She observed that, the girls had different priorities, for example: 'they enjoy talking as a purely social activity, and take far more interest in people than do boys'. Teachers need to be equable in the opportunities they bring to boys and girls, so that both sexes develop a wide range of knowledge and skills. They need, however, to be mindful of behavioral differences and varied interests. By singling out this example of the boys playing it might be construed that all play activity characterizes designing. A lot of play activities which Opie described revealed little presence of designing activity. There may have been a number of factors working against designing. The time scale of the recess break is very short and there seems to be a need for a period of reflection in designing activity, a factor which will be raised later in the text (Chapter 8). The boisterous nature of a playground environment might also have work against the need for reflective thought processes.

In summary, children's cognitive and social learning takes place both at home and at school. It is the purpose of school to promote the full development of student's concepts, knowledge, skills as well as responsible attitudes and values. There is some indication that learning takes place in children's play situations, and children clearly like to play. However, there is a need for research in this area particularly for longitudinal studies to get a better understanding of how children themselves think and feel about designing. Teachers can simulate designing and play situations in the classroom which promote designerly thinking and learning and some approaches to this will be discussed later in the text.

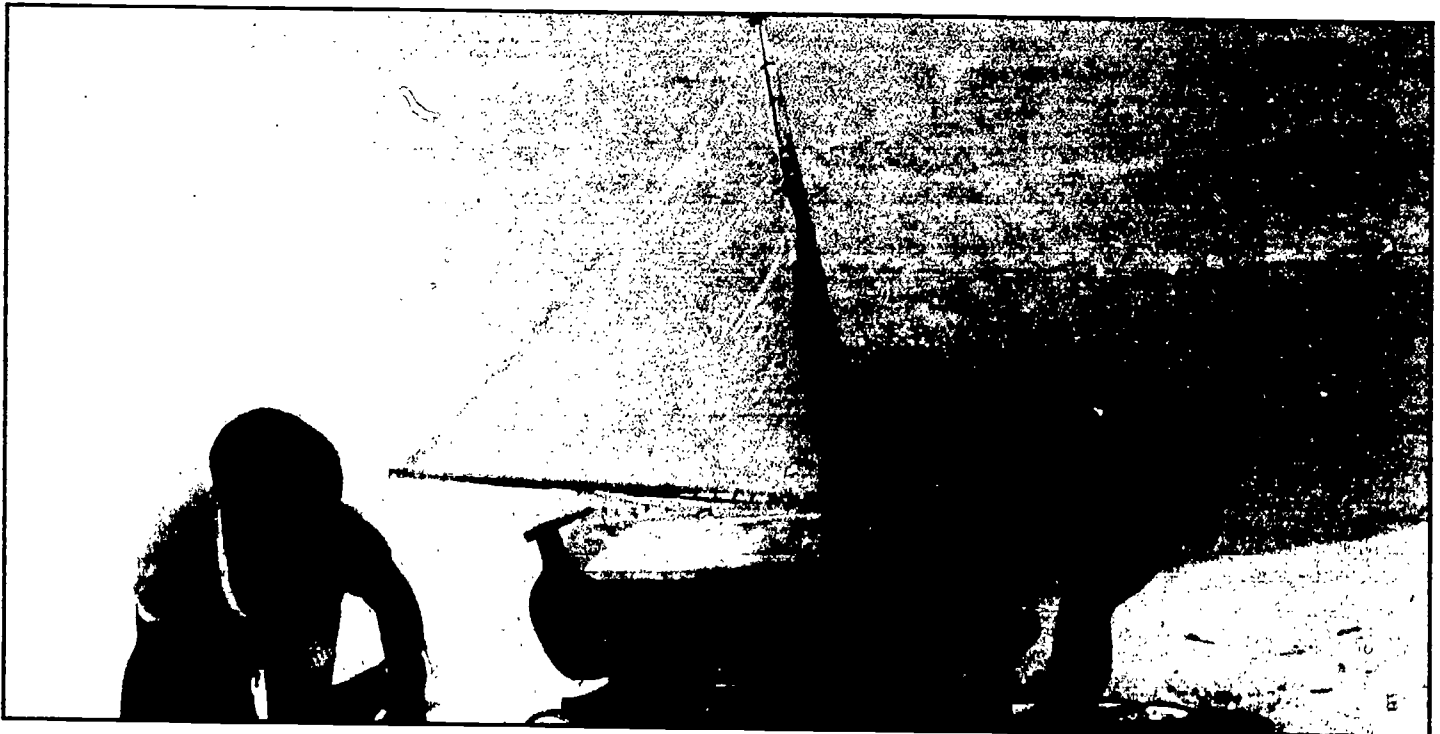
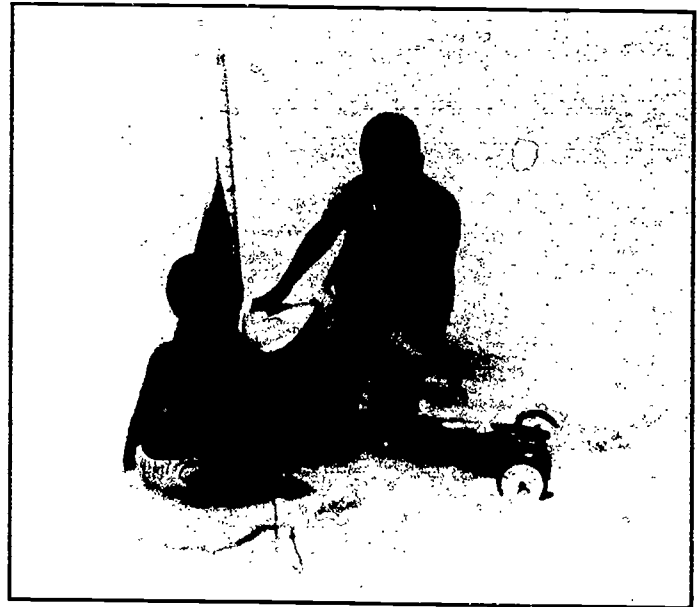

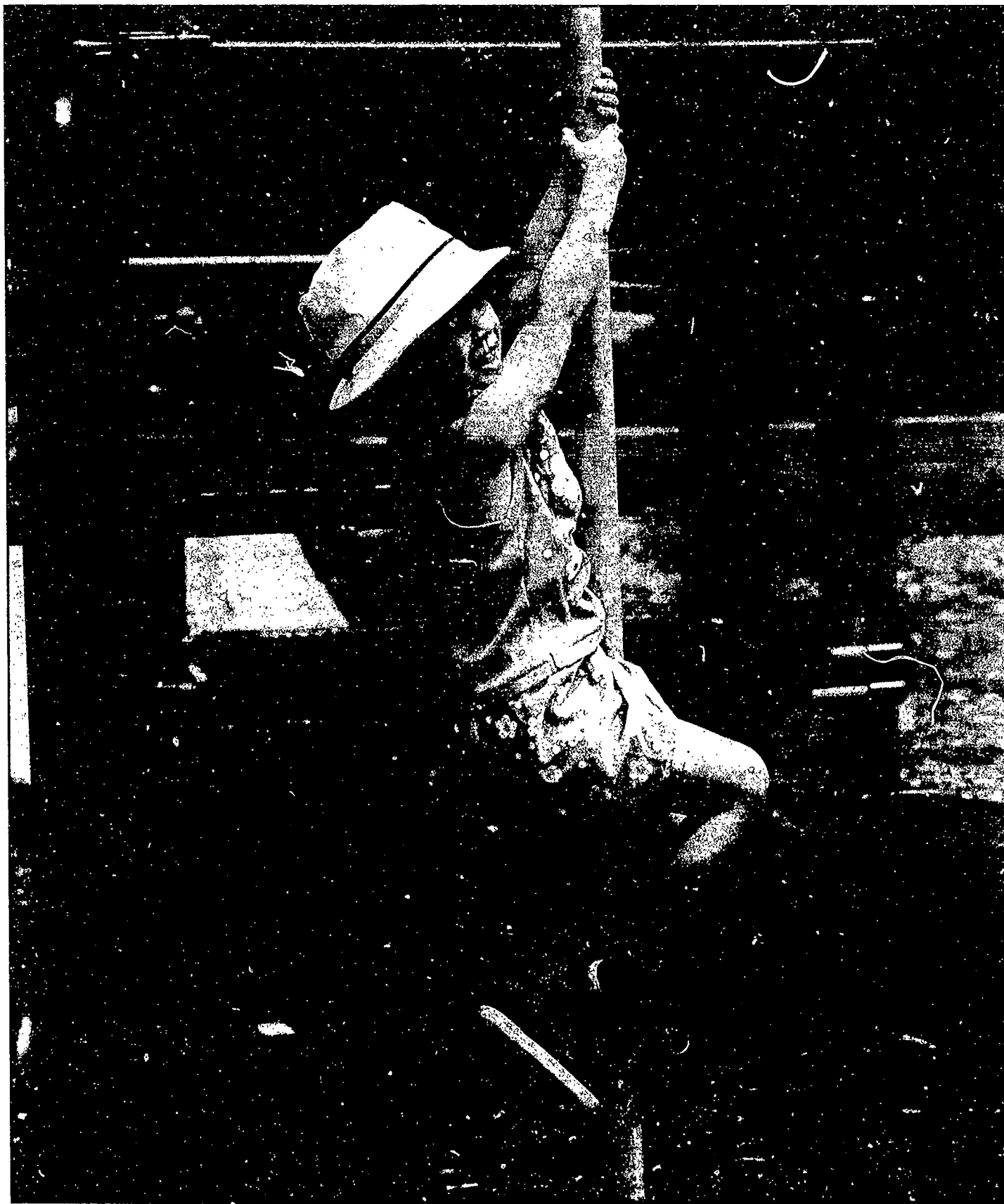

The capacity to design requires several distinctive abilities: to perceive, to image and to model

This young girl uses her senses to absorb her playground surroundings. We cannot see her private thoughts. She can use many forms to communicate her thoughts to herself and to other people.

Playgrounds designed by professional designers assist children's cognitive development. This girl may imagine she is a climbing animal or a firefighter descending a pole at the fire station. She can use bodily kinesthetic action to communicate her thoughts

THE ACTIVITY OF DESIGNING: the terminology

► *The terms: 'Design' and 'Designing'*

Design is discussed in the text as a broad field of human endeavor and enterprise which is analogous with science and the humanities in its generality and complexity. A selective list of literature on design studies is included in the reference section. There is no simple definition of design or designing, wherever possible the terminology will be discussed in relation to practical experience rather than abstract ideas.

In addition to design being a broad field of human activity, design is also a term which at one level relates to human response to the made environment and at another embraces a diverse range of areas of human activity. Each field of design, for example: architecture, graphic design, fashion design and communications is a distinguishable area of professional design activity. There are many kinds of design and many attitudes to design but there are some common elements which are the basis for discussion in this text. Archer's (1978) definition is broad and comprehensive:

'Design is that area of human experience, skills and knowledge that reflects man's concern with the appreciation and adaptation of his surroundings in the light of his material and spiritual needs. In particular it relates with configuration, composition, meaning, value and purpose in man-made phenomena.'

The term *to design* and *designing*, when used as a verb, is characterized as the intentional activity of humans, with their conception, resolution and realization of future configurations of the made world.

In this text designing will be discussed alongside the development of technological awareness as an educative activity at elementary level. The focus of attention in designing and technological awareness is the experience, purpose and intervention in the phenomena of the human made world. This publication emphasizes the cognitive and social learning that designing activity generates.

► *Design activity versus design educational activity*

Roberts and Archer (1992 p.3) make a distinction between design activity and design educational activity:

'Design activity, when distinguished from design-educational activity, is directed towards the manipulation of things and systems so as to achieve the most acceptable and practicable fit between a particular set of desires and needs, on the one hand, and a particular means of fulfilling them, on the other'. Design activity, they state: 'is more

concerned with the attainment of a result than with the acquisition of knowledge.'

'Design educational activity is concerned not only with achieving an effective result, it is also concerned with the development of the pupils' knowledge and understanding. This knowledge and understanding is to do with self, self in relation to made things and systems, and the appreciation of the effect of his or her own, and other people's activity in and on the world.'

The educational benefits that the boys gained on the beach (Chapter 1) were incidental to their goal of devising the most effective system to launch and sail their boat. A design educational activity that has been contrived in a classroom situation is concerned with achieving a result and with the development of knowledge and understanding by the students. This knowledge and understanding is concerned with the student as an individual and with the relationship of self to the world of physical objects, complex systems and the environment as a whole.

► *Design educational activity in school*

In school, design educational activity should be focused towards students' awareness and understanding of:

- their own physical and psychological needs and capabilities;
- the different needs and capabilities of others;
- how the existing environment has come about and how it might become in a future reality.

At the elementary level designing and technologically educative experience may take place across the curriculum where the timetable is less likely to inhibit this possibility. For example: learning about communications and robotics may commence in time allocated for science and technology. The activity can be extended into language arts, math, and art. When the class teachers have a major responsibility for planning the time table there is less fragmentation of the curriculum.

Chapter 4 describes a topic method where the design activities were integrative. Chapter 7 discusses a theme which enabled interdisciplinary learning. There are several subjects in the elementary school where design related activity may be developed explicitly: for instance in art, technology and drama. The staging of a drama production can involve all these three disciplines in designing costumes, sets, lighting effects etc.

► *Designerly thinking*

A designerly approach to an activity can be identified when human activity involves the use of mental and physical

thought and action through models, codes and symbols and is directed towards:

- making a response to a perceived need;
- the creation of something which did not previously exist, or the modification of something through invention and innovation;
- an intentional outcome even if only an ill defined idea;
- some pattern, coherence and structure in the course of the action;
- the manifestation of a system of values;
- The ways of thinking and acting characterize the way professional designers respond and act.

(This iterates the activity of the boys on the beach in Chapter 1)

In an educational context designerly activity involves these characteristics in promoting the interaction of the student with the physical world through the exercise and development of the cognitive modeling capacity. The activity takes place over time and demands periods of reflection and evaluation. The outcome is a compromise of the accumulative demands of the activity, the age and experience of the student.

► **Design Capacity and Design Ability**

It was suggested in the opening chapter that the boys on the beach were using an innate capacity of all human beings. According to Archer (1992):

The capacity for envisaging a non present reality, analysing it and modelling it externally, is the third great defining characteristic of humankind, along with tool-making and language.

This capacity to design requires several distinctive abilities: to perceive, to image, and to model:

Perceiving depends on what we envisage and internalize from our experience of the world. Our senses play an important role here.

Imaging can be described as 'seeing in the mind's eye'. We all appear to have a capacity to picture something mentally and to describe what we picture in our mind to others. Our memory, powers of recall and ability to speculate are important in helping us to image.

Modeling involves manipulating a three dimensional configuration in the mind, even when it has been observed from one viewpoint only. This model in the mind can then be translated into a form that can be communicated to other people. For example: a person can have an idea for a box; can decide about its dimensions inside his or her head; can make it with whatever resources are available (paper, card, wood, clay); and show it to another person.

► **Children's design ability**

The boys on the beach illustrate how children see and respond through the eyes of their culture. They were using a model boat

and the phenomena of their surroundings to stimulate their thought processes. They were using their imagination and acting creatively in physical play. Outterside (1993) has suggested that children not only see and respond to their culture but exhibit curiosity about cultural meaning, the way things are done, how people behave and what things look like and represent.

In another observation of child activity:

One sunny Sunday afternoon in the park of a bustling capital city, a small girl of perhaps five years old stands by a low wall, while her mother sits chatting to a friend. The girl has a box of colored plasticine balls and is preoccupied with molding round shapes, elongated strips, composing and ordering a pattern with them. The observer wondered what she was representing, but having no Spanish was unable to inquire. On looking across the path, beyond the child, the subject of her fascination became apparent. There was a row of vendors, their wares arranged on the ground: jewelry, scarves, ties, and socks.

This is an example of a child outside school without adult intervention demonstrating an emerging awareness of design. She demonstrated a visual awareness of her environment; **perceiving** order and connection in the complexity of wares in front of her; picturing a simple system in her mind (**imaging**) and describing it through modeling clay, creating a system of symbols to represent her surroundings (**modeling**). The model she was making stood for what she saw.

► **Professional design ability**

Not all human beings have the same measure of ability or inclination to design. Just as it is acknowledged that human beings have different ways of knowing and understanding (Gardner 1983) they appear to make individual responses to their designed surroundings. Some individuals have special talents and demonstrate outstanding capability in designing. Even among professionals with expert skills however, the breadth and depth of their designing ability varies.

► **The language of design**

The separate fields of design activity, for instance architecture, fashion design, industrial design, graphic design, communications etc. each has its own specialized knowledge and skill. Designers need verbal and mathematical skills when they are designing. There is, however, a universal language of design which is similar to mathematics and links the different areas. This language which involves non-verbal communication, is an important element linking all the arts. *Learning by Design* (1987) is an environmental education program of the American Institute of Architects which covers visual language development in relation to architecture.

A person's design ability would be shown through the use of this language by making a qualitative response to:

DESIGN VOCABULARY

Design ability is expressed by the use of the language of design.

FORM

This diagram illustrates the visual vocabulary of designers. These elements can be expressed through non-visual means: e.g. music, words

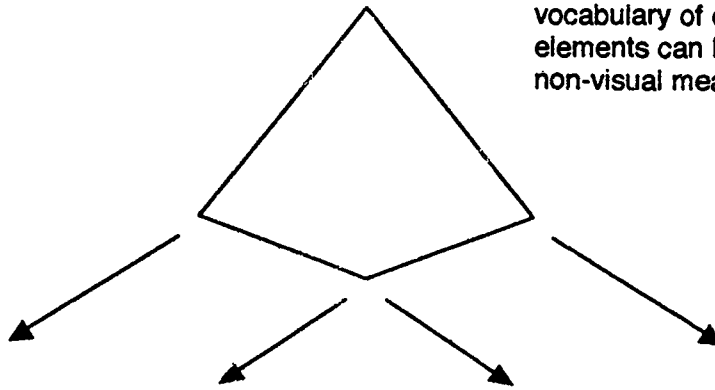

SHAPE



LINE/STRUCTURE

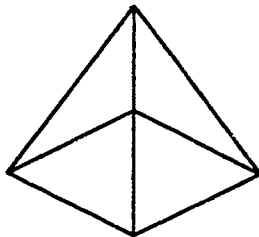

TEXTURE

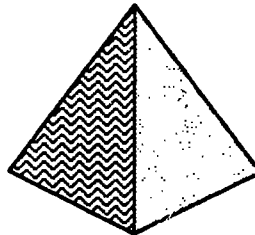

COLOR



and SIZE

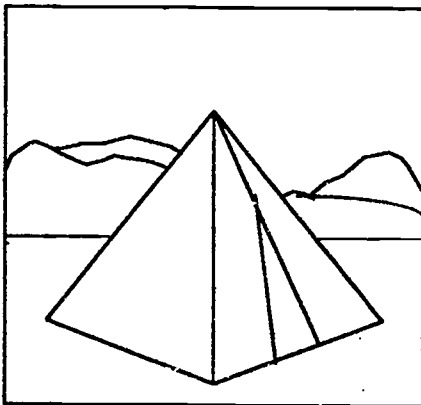

SPACE

and an understanding of proportion and scale is necessary in designing a tent.

ORDER AND PATTERN

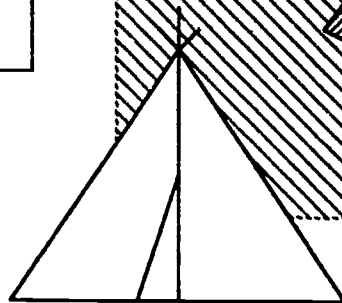
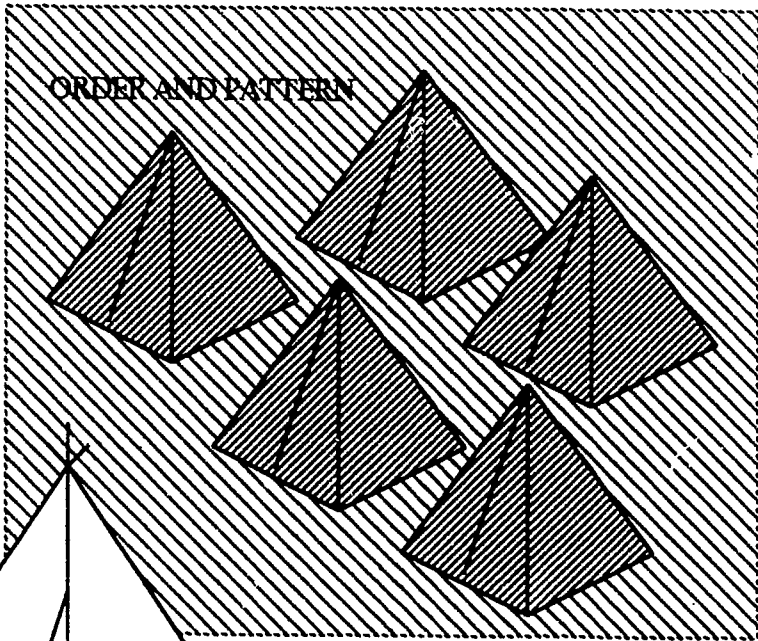

SYMBOL of a dwelling has cultural meaning

A tented camp may be arranged in some sort of order so that people can find their way around.

- **form.** All designed phenomena has form. The understanding of form is embedded in perception as discussed later in this chapter. Shape, line, structure, texture, color express the value of the form. Form can be portrayed in many kinds of styles. (The illustration shows the simple development of a geometric triangular form).
- **space, and an understanding of proportion and scale.** All designed phenomena occupy space. People can enclose space (e.g. buildings), and travel through space (car, air-plane). Form and space are related in objects communications systems and in environments. For instance the size, space and proportion of a tent (see illustration) would be related to the need of the user. All types of designers are concerned with scale, proportion, ratios, modules etc..
- **time.** All designed phenomena exist in time and are affected by time. Everything made is subject to change. For example: over time, made objects may rot, decay or go out of style. Some designed phenomena are made to create new possibilities for people, for example: labor saving appliances, means of travel and communications.
- **symbolic meaning:** people depend on externalized signs and symbols to develop thought and communication with one another and identity. Symbolic meaning can be found in all designed phenomena. (The diagram shows a tent which is the symbol of shelter and of a cultural building tradition).
- **and a sense of order/pattern:** people arrange the form of their environment to suit their needs. coherence and unity take on meaning as humans organize objects, systems and environments. (a tented camp might be arranged and numbered so that people can find their way around).

► **Children perceiving**

Younger children who cannot express themselves as easily as older children, can demonstrate their knowledge of the world through a variety of media. As children grow they develop a visual schema of their surroundings. They begin to learn the language of design. They can personally envision a chair or a house etc. Outterside (1993) states that children cannot begin to visualize what might be if they have no perception of what is. In her investigation of young children's emerging design ability she reports instances where children see not only through the eyes of their own culture but construct their own visual schema. A shape which she drew, thinking that a three year old might see it as a bird, was recognized as an ice-cream. The child turned the drawing around ... it became a space rocket.

De Bono (1991) believes that the relationship of perception to thinking is crucial and he defines thinking as: '...the operating skill with which intelligence acts on experience'.



Age 3.3 "Icecream"
 Age 3.4 "Lamp"
 Age 3.5 "Icecream" (This schema remained uncoloured at this stage). I asked Joe if this was the right way for icecream to be. He said no, that it would fall off.
 Age 3.6 "Icecream" (Again I asked Joe if this was the right way for icecream, so he took the card and turned it around.)
 Age 3.7 "Icecream, but watch, icecream goes like that" (Again he turns the card around.)
 Age 3.8 "When it's like that it's a icecream" (Turns card around). "When it's like that it's a space rocket" (This reference to space rocket indicates Joe's particular mind set at this time. He is heavily influenced by Thunderbirds and Button Moon.)

The language of design : a visual vocabulary

Children imaging

Imaging involves acting upon our perceptions. It is concerned with the ability to mentally visualize our previous experience (use memory), perceive what is in present time, and to construct what might be in future. Baynes (1992) suggests that quite young children can image. Outterside believes children as young as 15 months are capable of imaging and cites a child holding a toy and pretending to lick saying 'Umm, Candy'. The toy stood for something else, the child was engaging in mental imagery.

The girl in the park also showed capability of mental imagery, modeling directly from perceived experience. From about three years children show signs that they can visually memorize and talk about something they have experienced and become aware of their ability 'to remember' (Gardner 1983, Outterside 1993).

The boys on the beach were using existing knowledge to visualize how things might be. They were thinking creatively about what they might do next and visualizing processes rather than a product. When children can form mental operations is controversial: Gardner (1983 p.179) says they remain static in early childhood. Outterside (1993) on the other hand relates a vivid example of modeling by a four year old moving a DUPLO® person in the air:

The man is flying in the big balloon, but he does not have enough fire to get down. He was asked, "So what does he do? Can he get down?" Joe said, "No, because he isn't heavy enough to come down". Joe was then asked if the man would have to wait until he drifted down. "No", replied Joe, " He will eat his dinner, then he will grow bigger and he can come down".

He visualized the processes whereby the man would grow bigger and heavier as a result of eating and cause the balloon to descend. He used his existing knowledge of life's processes and applied them logically in the context of play.

Modeling: the ability to make something stand for another is discussed in the next chapter.

3

COGNITIVE MODELING: A distinctive capacity of the mind

Central to the act of designing is the capacity to image ideas in the mind and translate these ideas into a concrete form that can be communicated to other people.

The expression 'cognitive modelling' is intended to refer to the basic process by which the human mind construes sense experience to build a coherent conception of external reality and constructs further conceptions of memory and imagination. The expression 'imaging' is intended to refer to that part of cognitive modelling which construes sense data and constructs representations spatially and presentationally, rather than discursively and sequentially' (Archer 1992)

A model is anything which represents anything else for informational, experimental, evaluative or communication purposes. Drawings, diagrams, number, language, computer programs, musical notation, 3 D models, plans, and maps are all models of various kinds.

A feature of the human mind is that it is predisposed to seek similarities within and between its accumulating conceptions, and to assign these to categories.

Young children are disposed to representing the world that they experience through models, such as primitive drawings and even by arranging food on a plate to represent something else. Drawings and model making with available material are ways that children can communicate before they are able to speak.

These models take on different meanings at different times. The brain appears to organize itself into patterns and the child uses the same pattern over and over again quite effectively. They demonstrate how they perceive space, shape, size and proportion of their surroundings. By arranging and rearranging objects close to hand children learn to make choices of, for example, toys. They also make it quite apparent if they dislike something, e.g. the taste of certain food.

As children develop they become aware of concepts such as basic colors and shapes. They learn to name the colors of, for example, a bunch of balloons and the shapes of windows. They will be able to apply the color and shape notation in other contexts: flowers, cars, clothes etc. They build up links between concepts of shape, color, materials and categories e.g. balloons, food, flowers, plastic objects. They will be able to describe the shapes of windows, the color of shutters etc. Through this gradual development rational thought develops. It is through exploring concepts and categories, recognizing relationships and links that designerly thought emerges.

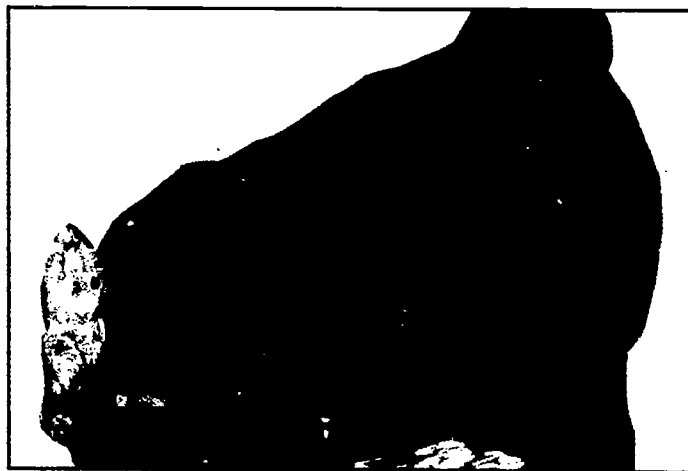

The student is visualizing what kind outfit to make for the teddy bear in response to the problem—Teddy has nothing to wear for the party'

Children develop symbols or schema to represent these conceptions, categories and relationships. The use of symbols enables the abstraction of inner thought, and externalization of thought processes for recording or communication purposes.

► A theory of multi intelligences

Gardner (1983) put into focus the idea that there are at least seven different forms of intelligence: linguistic; logical-mathematical; spatial; bodily-kinesthetic; musical; interpersonal and intrapersonal modes.

It is a cognitive model which seeks to describe how individuals use their intelligences to solve problems and fashion products. According to Armstrong (1994 p.14), 'Gardner's approach is particularly geared to how the human mind operates on the contents of the world e.g. 'objects, persons, certain types of sounds, etc.' This philosophy of education is gaining more impact in elementary schools. 'How students think is becoming almost more important than what students think' (Armstrong 1994 p.146). Spodak (1993) suggests that a multi metaphoric approach to curricula should be available to children. In fact many alternative activity based programs are essentially multi-intelligence (Armstrong 1994): for example, cooperative learning strategies place emphasis on interpersonal intelligence, while the children can be using other forms of intelligence as well. Similarly, whole language has linguistic intelligence at its core. While studying a concept such as sound, students may have science, technology, music or art as a goal.



Kindergarten students are modeling a playground using manipulatives in the stand tray

► *Several forms of intelligence are used in designing activity*

Designing activity uses several forms of intelligence. Spatial, linguistic, logical mathematical, interpersonal and intrapersonal modes. It could be argued that designing involves its own form of intelligence, particularly modeling which sometimes gets bound up with spatial intelligence.

Modeling is a key to communicating design intelligence.

Examples of children's modeling

Two important media for thinking in school are drawing and construction kits:

- traditional art materials and computer software programs can be used for drawing. It is important that children have a regular and varied experience of drawing;
- construction kits supplied by LEGO Dacta, Modern School Supplies, Inc., Plastruct and many other suppliers may be used for modeling.

Observational drawing, annotated drawing (words and pictures), sketches, diagrams, charts, plans are all methods of representing design ideas graphically in two dimensional form.

Pencils, crayons, chalk, colored pens, photographs, videotape and graphics software are some of the media that can be used for graphical representation.

Modeling in a variety of materials such as card, clay, metal, plastics and fabric are ways of communicating ideas in three dimensional form. Construction kits are an important resource for communicating three dimensional form.

► *Computer aided design*

There are a number of computer aided design packages suitable for elementary grades which will simulate three dimensional form. Software by AUTODESK Inc., such as AutoSketch®; Apple Computer, Inc., CLARIS® for Macintosh; and KidPix by Broderbund can be used throughout the elementary school.

Each medium enables the student to think things through in his/ her mind and to communicate ideas to others.

Drawing

Drawing is a valuable thinking tool in designing and making activities, which enables students to analyse, formulate and convey their ideas. Sometimes there can be a problem if students are expected to draw their ideas before proceeding to other materials. Young children do not always want to draw something before making it. Their ideas can exceed their manipulative capability, and sometimes students do not have the ability to predict what a final idea will look like.

► *Observational Drawing*

Students from kindergarten upwards are capable of looking closely at objects and environments, analyzing, evaluating and drawing them. Through this kind of activity students develop an awareness of technology. Students used drawings to enable them to evaluate the materials properties, structure and mechanism of a product. This first grade student took off the clothes of the stuffed mouse to find out how it was constructed; how many parts there were; what it was made out of, how it was constructed.

Another student drew a lunch bag to find out about the materials, the way it was constructed and how it fastened. Both drawings realistically represent the three dimensional object, however the mouse drawing became more diagrammatical as the student explored the object.

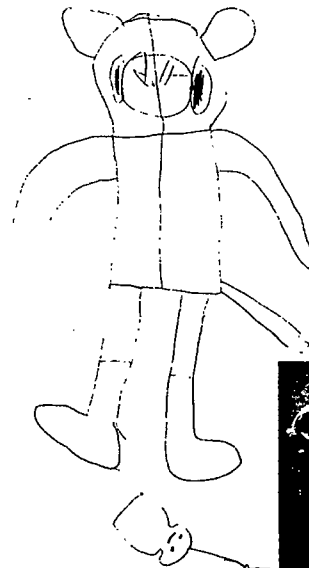

Students from kindergarten upwards are capable of looking closely at objects and environments, analyzing, evaluating and drawing them. Through this kind of activity students develop an awareness of technology

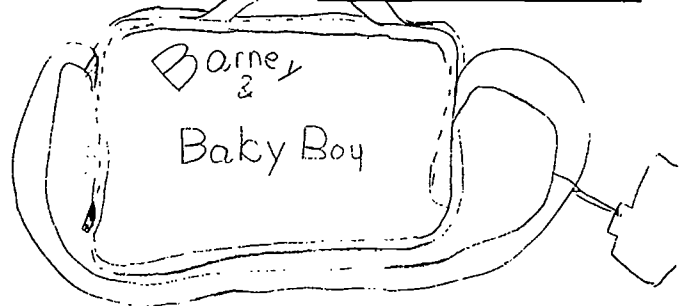
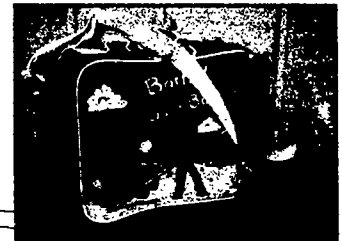

Students used drawings to enable them to evaluate the materials properties, structure and mechanism of a product. A first grader explored the stuffed mouse toy to find out how it was constructed. Another student examined a lunch bag

► *Recording an outcome*

Young students may benefit from recording their design after it has been made, particularly where ephemeral materials such as a construction kit have been used. This student

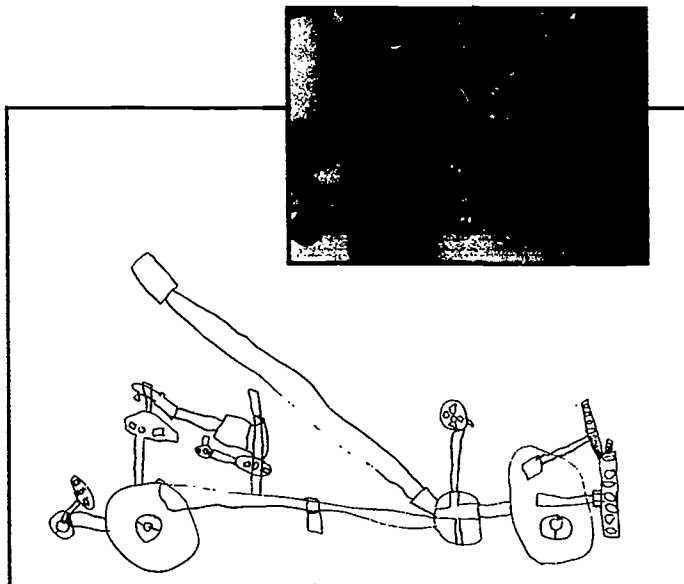

A drawing can be used to record what has been made. This student made a vehicle with two friends. Now he has a drawing of his own to remind him how it was made.

worked with two other students to create this vehicle. Now he has a drawing of his own to remind him of how it was made.

► **Communicating details, plans and ideas**

Students can focus on communicating details of what they see or what they envision in their mind. These details can be presented as annotated drawings, exploded diagrams, graphs or plans using traditional media or computer software. The scale of the drawing can be enlarged to assist communication.

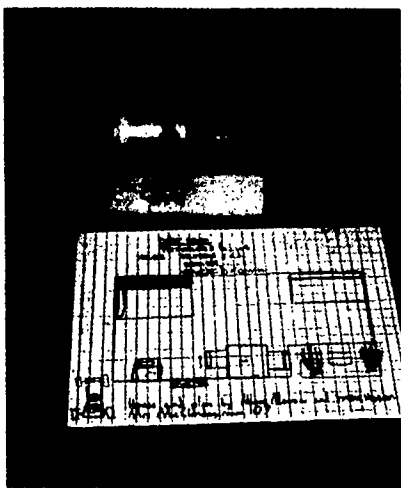

These students have drawn a plan to communicate their ideas and modeled the proposal with construction materials

Construction kits

There are many three dimensional manipulative materials such as clay, metal, and plastic, but space does not permit a full discussion of these. The construction materials that are widely available e.g. bricks, blocks, and cylinders are very important modeling tools. They are usually packaged to develop knowl-

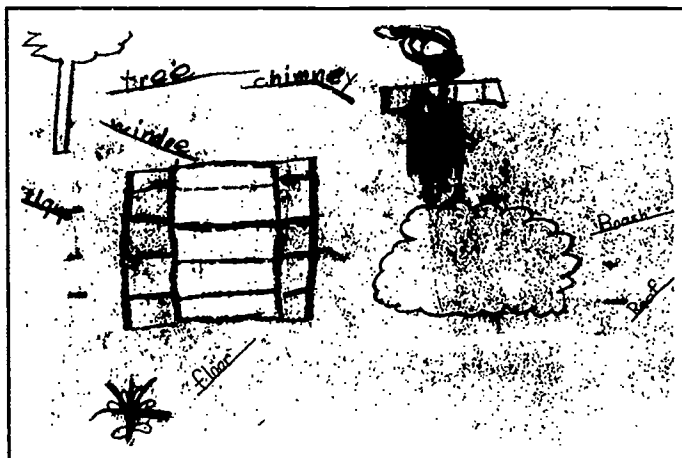

Details can be communicated through annotated drawings.

edge and understanding in math, science and technology. Their asset as a cognitive tool is not fully emphasized by the manufacturers and educational distributors.

These manipulative construction pieces should be used in addition to drawing as a medium for thinking. There are several kinds of ways that construction kits may be used as a cognitive tool.

► **Cognitive activity using a construction kit**

1. **A student can use construction materials as a spontaneous play tool.** Bricks can be moved about assembled and disassembled. One minute an imaginary tower is created and then an animal. Extra bricks can be added and taken away through simultaneous imaging and modeling.
2. **A student can follow the instructions, measure and count holes and match pieces** of gears, beams, pulleys and wheels. This involves logical and disciplined thinking which is also important in cognitive development.
3. A student may know what he or she wants to build and set out to construct what has been imagined. Soon the student finds that as the work develops construction kits have possibilities and limitations. **The student learns to compromise and solve problems.** During the course of the action he or she learns some principles about the way the bricks fit together, as well as some of the drawbacks of the medium. What can be achieved with bricks is very different than using card or clay for instance.
4. Having constructed something with a kit a **student may improve the structure or the performance of what they have made.** The structure may be modified, simplified or extended.
5. Using for example a LEGO DACTA® Control System and a Macintosh or MS-Dos computer **a student can learn to simulate a system** using Logo programming language. He or she can now engage in role play using the simulated system as a tool to work on command.

DESIGNERLY THINKING: designing activities in the context of topic work

► The topic

Designing activity is concerned with human needs and desires. They may be fantasy ideas or based on real life situations. Any topic concerned with the basic necessities of life, that is: food, shelter, or clothes will be one where there is scope for designing activity. Designing is a basic activity where humans respond actively to perceived needs in the physical environment.

The activities which will be described in this chapter took place during the spring term. The topic 'Farms' was selected by the kindergarten teachers for development by five kindergarten classes (each class attends half day, either a morning or an afternoon session). The topic had scope for developing emergent language and mathematics work using the many books and information technology resources in school. Stories about animals for example are a universal favorite with young children. The school was situated in a recently developed urban area with highways and streets denoting their pastoral origins. It is important to state that in selecting a topic activity it must be relevant to the children involved. This topic might not have the right focus for an inner urban child but the concepts are basically the same. Students might ask such questions as: 'Where does our food come from?' or, 'How does it get to the grocery store?' 'How is it stored?' and 'How can it be transported from one place to another?' Therefore, this topic would need to be restructured for other learning situations.

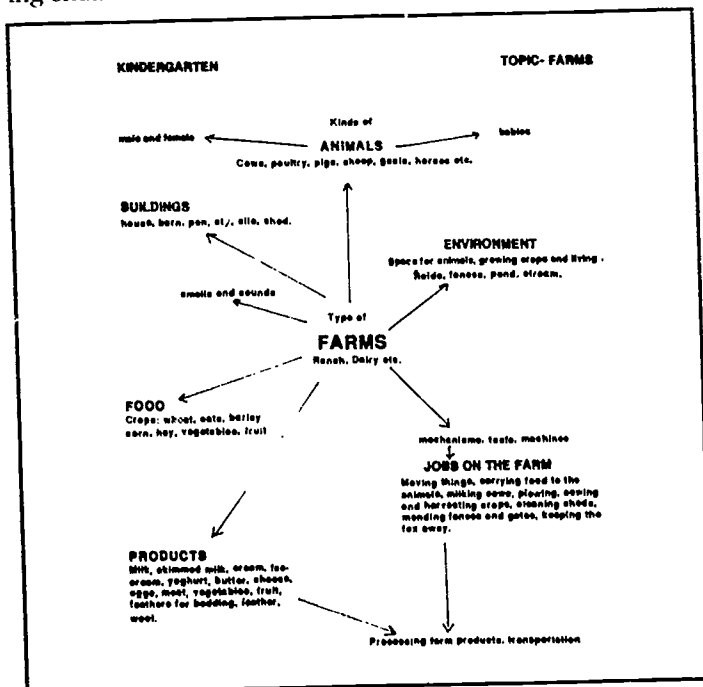

Topic: The Farm

DESIGN BRIEF

The Situation: the proposed activity

The Task: what the student is expected to do

Specification: details, time, materials etc.

A Design Brief sets out a description of a situation (real or fantasy). It asks students to do something in response to the situation (a perceived need, problem or opportunity). A design brief was used for all the activities described. With young students, it is not necessary to have a formatted design brief for young children.

The topic activity was sustained for a month and several curriculum areas were represented in the project activities: language arts, mathematical skills, technology, art, and music. Most of the activity was individually based with the exception of a few whole class projects. Each student compiled all their written work and drawings into a folder which was taken home at the end of the topic project.

The highlight of the project was a visit to a farm towards the end of the activities. Typically, the class teacher had three to four activity tables in each session, with some periods where all the class met in a circle with the teacher for focus and evaluation. As is customary in the county, there is a teaching assistant present. In addition, this school was fortunate in having the assistance of a parent volunteer to supervise some of the groups.

Design briefs relevant to the topic were developed by the teacher after initial investigative activity had taken place with the class. A Design Brief sets out a description of a situation (real or fantasy). It asks students to do something in response to the situation (a perceived need, problem or opportunity). A design brief was used for all the activities described. With young students, it is not necessary to have a formatted design brief for young children.

A design brief assists the teacher in structuring the activity. As students develop they can take part in devising their own design briefs and presenting their own format, making use of

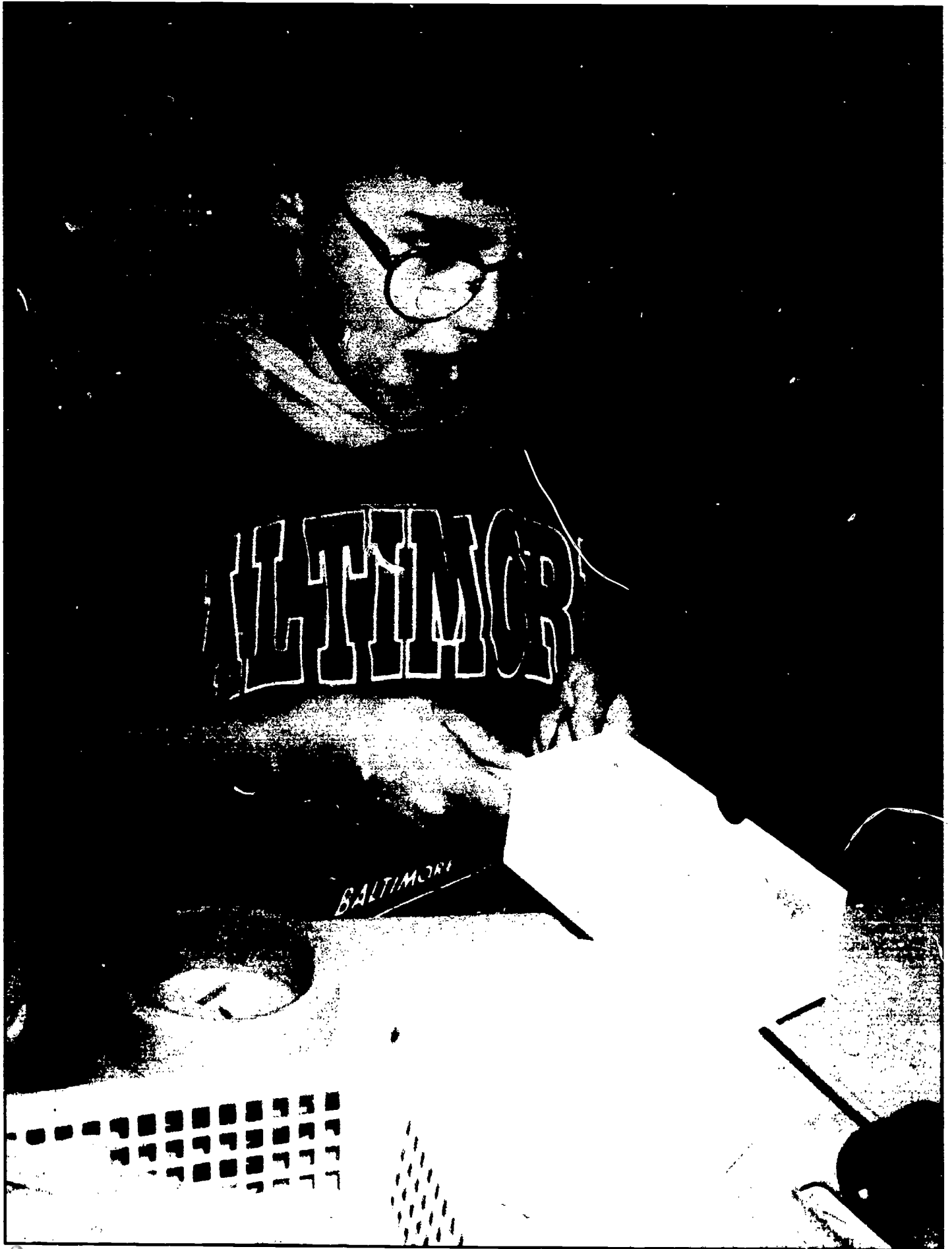

ERIC *Designing a cart to carry food to the animals. The vehicle passed the test!*

a computer to layout the specifications (see Chapter 5 for further information).

► *Activities which develop designerly thinking*

Four activities are described which illustrate the development of designerly thinking in young students:

1. **Thinking about need: spaces and places** are concerned with thinking about spatial relationships;
2. **Carrying people or objects from one place to another** is about transportation;
3. **Identifying the purpose and function of farming** focuses on what farms do and what they are for;
4. **What we need and where we can buy it: farms work for you and me** demands thinking about retail and consumers.

1. *Thinking about need: spaces and places*

Any examination of the human physical environment will show that human beings seem to need to organize areas and spaces. A typical house has rooms for certain human activities. Sleeping often takes place in a separate room or area from eating or cooking. In the neighborhood there are spaces for houses, and for traffic and for shopping etc. There are places where children are not permitted to go. There are places and spaces that are dangerous to enter. People mark out the parameters of this existence by creating boundaries: a house will be represented by walls; in the neighborhood there are fences, walls, posts, wires, that set aside one space from another. Some spaces are marked by invisible boundaries. It is difficult to create walls across countries, though some states have tried (for example, the Great Wall of China). Imagine trying to put a wall around each state, or county of the United States. Sometimes there is a natural border such as water or a mountain.

People can represent these boundaries on plans, maps and charts (which are forms of modeling). Adults usually know where it is permissible to go; children have to learn about it. They may have to be told that playing on a railway track or near the highway is not a good idea. A whole realm of activities might be evolved from this subject. Just think for instance about board games, chess, chutes and ladders etc. They are all about moving into spaces and commanding territory.

► *The need for spaces and places on the farm*

Farms like any other form of human organization have places for people to live in, places for animals, places to grow food and places to store food. If you have seen a farm from high ground, or from an airplane, farmland is a patchwork of

spaces and places. The first activity was planned around a basic concept of places and spaces that farms need.

Activity. The aim here was to encourage students to think about farms, about the environmental organization of a farm and to consider spatial concepts. A few students in this experiment had prior experience of visiting a farm, others had prior knowledge about farms which had been acquired from books and television.

¹The purpose of this activity was to identify the needs of farmers by organizing farm buildings and space. To help the students visualize a farm, a simple model of a farm building was placed on the classroom floor, along with some model animals and strips of green construction paper and corrugated cardboard.

► *Encouraging the ability to image:*

The students were asked questions such as: What do you think happens in this house? Where do you think animals could go to feed? What do you think they like to eat? What kinds of food could the farmer grow? These propositional questions elicit responses, some expected and others which are not. These six year olds had no problems in thinking visually about farms. Children are able to image, that is 'to see in the mind's eye' from birth and this ability seems to be innate. These mental perceptions are formed through perception of the surroundings and are shaped and developed through experience.

► *Encouraging the ability to imagine:*

This kind of thinking is developed by telling a tale about the problems that the farmer is having. In this instance a simple fantasy story based on a reality situation was related to the students:

The cows are trampling down the growing crops and the sheep are nibbling the long grass which the cows need to make milk. How can the farmer separate the animals? What can the farmer do?

► *...and to speculate:*

Having imagined the problem students can be invited to speculate about what could be done about the situation. They can think about it but this is a good opportunity to share some ideas with others. This can be done by encouraging the students to talk about their private thoughts, to test ideas out on others and to consolidate and develop them through discussion. Baynes (1992) describes speculation as the controlled and deliberate use of imagination and believes that it can be learned through practice, teaching and experience. It is a key to developing creative thought. Students at this stage of development are unlikely to worry about what

¹ 1040 DUPLO® Farm and 1043 DUPLO Farm Animals could be used for this purpose. Other DUPLO sets could be used similarly for other topics. For example: DUPLO Community and DUPLO Home Environment sets.

task is feasible or not. As they develop they reach a stage where they can keep reality and fantasy apart. It is important to foster the imaginative facility that children display in their play through adulthood.

Activity 1:

The activity was introduced to a large group. The students were encouraged to identify needs of a farmer and of farm animals and to imagine the surroundings of farm buildings. A design task was presented as a problem that the students could solve in pairs.

Key words: fields, fence, wall, ditch, hedge, water, gate, animals, crops.

Design Brief:

The farmer needs to create fields which separate the cows, the sheep and the crops. The sheep nibble the long grass needed for the cows and the cows trample the growing crops. Design separate spaces for the cows, sheep and the crops. Make sure the animals cannot stray.

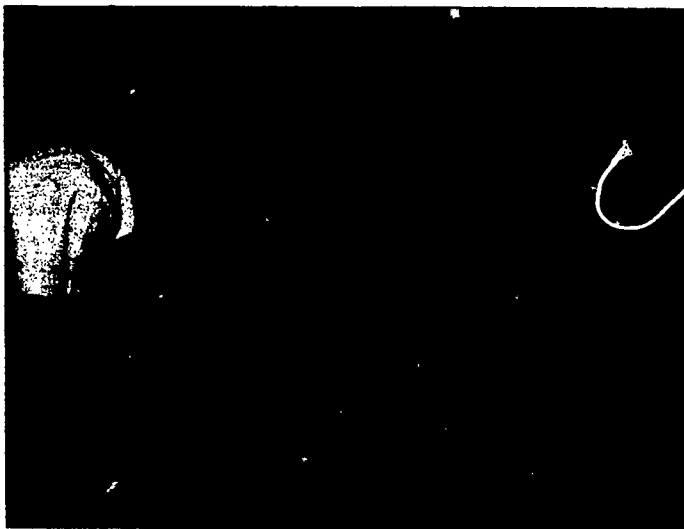

Spaces and places for animals to feed and for growing crops

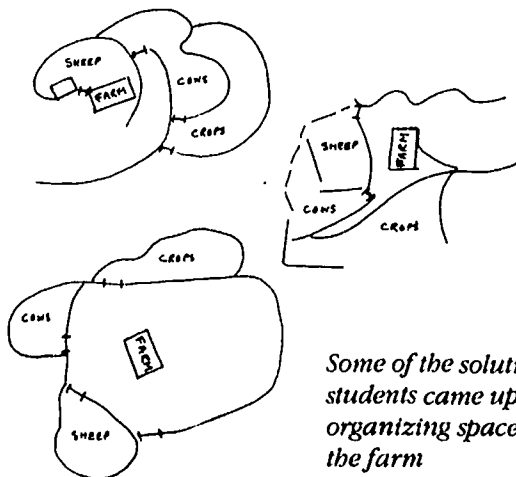

Some of the solutions that students came up with for organizing space around the farm

► **Modeling thoughts and ideas and sharing them with others**

At this stage of the action the students were encouraged to represent their ideas about what to do at the farm. This kind of designerly thinking involves skill in describing private thoughts in the mind and translating them in a way that others might share. Students have a number of means of communicating. They can communicate verbally, sharing their thoughts and ideas. They can represent the world through models which are symbolic in character. They might use for example, blocks and sticks to represent something and another minute later, the meaning of the symbol has changed.

Two approaches were presented to the students. Both involved models:

1. think, discuss, model ideas directly using the model farm house, the paper, card, scissors and masking tape to represent their solution. Draw a diagram of the solution after modeling it with manipulatives in order to share ideas with others;

alternatively:

2. think, discuss and draw the design on paper. Then create it from your design with paper and cardboard on the model farmhouse site.

It was anticipated that the direct structured play with the farm model would be easier as the alternate form was more abstract. This proved to be the case. Some students made interesting diagrams but were unable to translate the diagram model into the three dimensional concrete model. In this activity the skills involved in manipulating and manufacturing boundaries for the farm were relatively simple.

The students worked in pairs. Some discussion overheard: What shape are fields? 'Oval, square, round, sometimes the shape of a letter'. 'What would happen if all the animals were put in one big field?' 'They wouldn't have enough to eat'. 'They might fight and we would have to separate them'. 'Wait Becky I have an idea. This can be a river, the animals can run through this pipe to the river and drink from it'.

► **Learning to appraise and evaluate what has been done**

Thinking about what works and why is an important aspect of designerly thinking. From an early age children have strong views on what they like and dislike. This ability to self discriminate can be expressed. The ability to make choices can be exercised in these tasks. In this task the students have been asked to think about the issues arising in a particular cultural environment: the farm. Did they solve the problem for the farmer? Was there enough space for the crops, the sheep and the cows? Did they think about where to put the gate to each field? These are questions which can be asked about the student's own activity. The students can begin to learn from analyzing and criticizing their own activity. For example: was

it better to plan by constructing fences first or through drawing a diagram?

2. Carrying people or objects from one place to another

There are many situations when a load is too big for one person to carry and students need to think about this basic human problem. There is a vast history of transportation which could generate ideas for many other topics appropriate for designing activity.

For example, in the context of a farm there are several situations which could be the focus of designerly attention. The second activity was planned around the concept of the need to transport food on the farm.

► Discussion with the whole class encouraging thought processes about the concept:

What kind of things need to be lifted and carried: People? Animals? Crops? Food for the animals? How can food be carried to the animals? What kind of vehicles might be found on a farm?

Activity 2:

The aim was to help the students to conceive a construction or arrangement that would meet the specified need. The students were given a Design Brief, which set out the problem that they had to solve: to invent some means of transport to take food to the animals. This activity which focused on product design is fairly typical of problem-solving, outcome oriented tasks which link designing activity with technological knowledge and skill. The design need emerged from the investigatory class discussion:

Design Brief:

The animals are kept inside the sheds during winter. The tractor and trailer are too big to move inside the building. The farm manager needs you to design a small vehicle to carry food to the animal feeding stations. Make a model from the materials provided.

► Introductory discussion

Each group comprising of between six and eight students examined the design brief and thought about the problems, and imagined what might be created:

What is the farmyard like? Is it rocky, bumpy, muddy?

What kind of vehicle would be suitable? Think hard about whether it will be pushed, pulled, rolled, carried.

What kind of vehicle could you make?

This elicited the response: wheel barrow, food cart, food truck, food trailer etc.

Then students needed to be encouraged to think about what they knew, and what they must find out in order to do the task. Questions need to be presented to draw out their understanding of technological facts and what they perceive they will need to do.

This might elicit some of the following information: vehicles have one or more wheels and the wheels turn on an axle; there has to be a way to move the vehicle; if there is no motor there has to be a place to hold, pull and push; vehicles have a container to carry things. On this basis the teacher can set out the detailed specifications. There are two aspects which will be taken up when discussing the role of the teacher:

- How prescribed should the specification be?
- How much technical instruction should be included during the activity?

These issues are discussed in Chapters 5, 7 and 8.

► Design Specifications:

Make a model vehicle. It must have one or more wheels. There will be no motor so you need to think about the way a person will move it. The vehicle must be capable of carrying food.

Work in pairs or independently.

Materials available for modeling: circular shapes (lids, mats, bottle tops of metal, wood, and plastic); wood doweling, plastic tubing; various cardboard boxes; wooden lollipop sticks; masking tape; pencil and paper.

Equipment to be used in the activity area under supervision: saw, scissors, hole punch, hand drill.

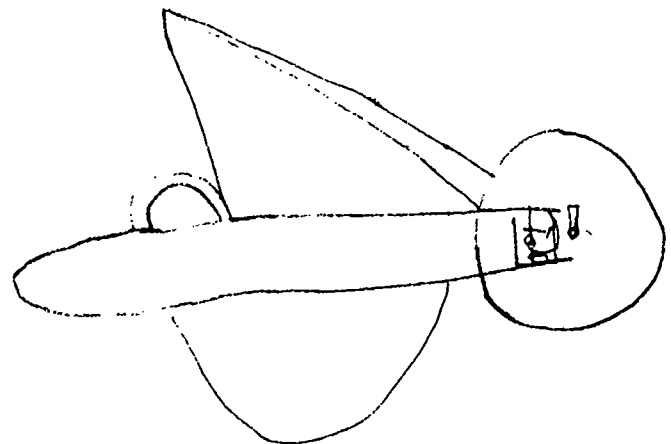

► Procedure in doing and making

The students set about the task either individually or in pairs. This involved speculative thinking about the intended outcome. The students were challenged to imagine what shape the vehicle might be and what size and kind of materials they would use. Planning the process of operation inevitably

involved thinking ahead, finding methods that worked, thinking again about the goal they had been set. Making choices about materials and tools involved design thought processes. When two students worked together they had to make decisions with regard to the other person. Sometimes a risk had to be taken, different solutions to be considered to see if they worked. There were problems for some students which they had to overcome in the process of meeting the goal.

What is being described here is a microcosm of the complex nature of the physical world and systems that humans find themselves in. The purpose of design thinking is to help the developing student to perceive order in undertaking a complex task, to begin to make connections, to see order and pattern, and causal effects of human action.

► *Students' attitudes to the task*

Young children tend to think out what they will do in the course of the action, the planning and making of the vehicle were interwoven. Some students started with the wheels problem, others with the container and handles. They planned perhaps the first step and then thought about what to do next. The response that students make to the task depends largely on their level of experience and development. Students are likely to work more comfortably in the range of skills that are familiar to them. Teachers need to be aware of this but at the same time need to assist thought processes that enable students to extend what they know and can do.

Teacher intervention will help students to anticipate what they will need to do so that students start to think ahead about information that will be required. Teachers can help students persevere with the task; learn to avoid problems; revise their plans when things go awry; be enthusiast and encouraging; develop confidence needed to take risks; provide the material or tool, or information that makes a difference to the smooth running of the action (see Role of the Teacher, Chapter 8).

► *Evaluation and testing*

Evaluation of the activity is not something that happens only at the end of a task, it should be an integral part of the process of reaching an effective solution to the design brief. The vehicle had to roll with ease to negotiate the bumpy surface of a farmyard; it had to have handles that one person could maneuver; it had to fit between the doors of the farm building; it had to have a container capable of holding food.

Each aspect had to be tried and tested. Holding the animals' foodstuff was agreed to be the most important feature. The students modeled the amount of food by pouring oatmeal into containers to estimate how much their vehicle would hold: Would it hold half a cup, a whole cup or more? They tried different containers. They needed to use number and weight relationships to do the design task. Here was an instance when mathematical thought and action applied to a design task. When the container is attached to the structure,

does it work i.e. move with ease? Does the vehicle balance or is it inclined to tip over? Does it hold all the food you want to transport? Here the students had to apply knowledge and understanding of the forces of weight and balance to the task. They had to utilize scientific knowledge and skill to accomplish the task. In evaluating the product, the key questions in appraising the outcome were: Is the solution what you intended? Did it work effectively for you? Do you think the farm manager was pleased with the result?

During the design activity teacher intervention can support the development of evaluative thinking and keep the activity on track by asking such questions as: Why did you do this? What was the purpose of this decision? Students need to be encouraged to think reflectively about what they have done and why they have done it in order to move forward. This should always be a part of the process.

* This activity took about an hour for each group. They came to a work station in the room. Not all students did the activity on the same day.

3. *Identifying the purpose and function of farming*

What happens on farms and what do they do? This is the main focus of the class discussion. This activity and activity 4 were devised to develop both collaborative and cooperative attitudes to a design task. They were designed to lay a foundation for understanding that in the world many aspects of life are developed as a result of people working together for themselves and for others.

► *Cooperative and collaborative approaches to learning*

So far the activities described have had an individual or shared (work in pairs) outcome. The students followed the same task in a group and made individual responses, only the paired students could be said to be working cooperatively. The following task describes students working as a group. **Cooperative activity** describes a task in which the students work on an individual assignment and then put their outcome together as a joint venture. In a **collaborative task** the students work on the same task and there is a single outcome.

There are elements of cooperation in both the following assignments

Introduction. What kind of things do farms produce? This question was discussed first with the whole class, seated in a circle with the teacher. The students passed around some products of farms, for example: a fleece and spun wool, duck-down in a pillow, milk and container etc. Handling the products gave the student an opportunity to use vocabulary related to each object.

► *Designing food product containers*

The focus of the activity task was dairy products. The students had previously studied 'the food pyramid' and understood and knew what dairy products were.

Each group of seven students spent approximately one hour at the activity table. Available materials included: a selection of commercial dairy containers, scissors, adhesive, pencils, felt pens, colored construction paper.

Activity 3: This activity was designed to develop a system for selling a product. The teacher set the design scenario:

Your farm has a milk testing station and is able to sell dairy products with its own label. Choose suitable containers for milk, butter, cream, yogurt, ice-cream and other dairy produce. Decorate the container with information about the product.

The group of children were asked to make three decisions as a group:

1. What will you call the farm?
2. What colors will you use on your dairy containers?
3. What would be the best shape for your labels?

(this gave an opportunity to reinforce learning developed previously).

► *Generating ideas through negotiation*

The teacher initiated the discussion by asking the students to remind her what dairy products were and to name some dairy foods. Each of the questions was discussed by the whole group and when a number of ideas had been put forward a consensus agreement was taken. Sometimes there was a vote. In the first group there were four votes for a trapezoid shaped label, two for hexagon and one for a circle. The trapezoid bid was carried. The students made similar decisions about label colors and trade names. Names such as Fun Farm, Kid Farm, Franklin Farm and Cornstock Farm were invented by the groups of students. There was some discussion about why it might not be a good idea to choose a color or shape that looked like the design of another group. In the competitive world, products usually need to look distinctive. Sometimes there was a vote and a majority decision was taken.

► *Procedure*

The students had four containers to create in the time available. They could work singly or together. Most of the students enjoyed working cooperatively with a partner in this collaborative venture. Each group produced containers for milk, yogurt, butter, cheese or cream. Some students made choices between 1 % and 2 % milk, or considered sour cream. They used skills that they had already acquired to decorate the container. They found that while templates were useful for cutting around shapes, the size was invariably wrong for their container. They had a number of problems to sort out in cut-

ting, assembling and then writing symbols and words on their containers.

The students then worked individually or in pairs to design and make their examples of containers for the group's model farm. The name, colors and shape had already been decided. A range of waste containers was available and the students chose a suitable shape for their example. Each group had to make sure they were designing containers for all the main categories of dairy products i.e. milk, butter, yogurt etc. In some instances they needed to cover the existing lettering. They needed to think about the relationship between the label and the overall shape of the container; placing lettering; illustrations etc. This activity involved independent thinking. It also involved an awareness of a product as part of the whole process.

► *Evaluation*

An evaluation was made of the outcome of the activity. Does the product show the name of the farm where it is produced? How can you tell what is in it? Is this a good shape for your product? Does it have the color and shapes agreed by the whole group? What else can you tell us about your design?

4. What we need and where we can buy it: farms work for you and me

Activity 4. This activity is arranged to connect the purpose of the farm to an every day system of living: going to the stores to buy what is needed. **The design task involved simulating a farm store enterprise and was an extension of the previous activity.**

Designing and role play: a store.

The products of the group design project were placed in the dramatic play corner. This was converted into a cooperative store where the dairy products of several farms in the community were sold.

The proposal to convert the dramatic play corner was discussed with the whole class. What does this store need? What sort of space? Who will be selling? What will they do? How will the dairy products be kept? Will they be kept warm, chilled or frozen? How can we keep a record of what is sold and what is bought? What sort of people will buy the products? Will they use money or a bank card? Which products will be popular? How will they carry their purchases home?

This task was organized similarly to the previous activity. Each group of seven students had a one hour session in the play corner.

Apparatus included: furniture belonging to the area; a cooler box to serve as a refrigerator; dairy containers they had made, shopping containers, money.

► **The scenario to be enacted:**

A new farm store is to be opened selling dairy products from many farms. One group will organize the store and sell the products, and another group will be the customers.

This activity was an example of managed, purposeful role play where students had an opportunity to design a scenario and to enact the preparation, organization and transaction of a business enterprise. They also needed to work cooperatively in this venture.

► **Assignments**

The tasks were organized into sub groups:

1. Designing and making the store space.
2. Keeping data about stock.
3. Managing the refrigeration zone.
4. Managing the cash register.
5. Planning the shopping expedition

Students volunteered to take responsibility for stocktaking; organizing the cold storage; pricing and selling goods; managing the finances; making shopping lists; choosing the best products. Most groups identified the need for a manager. One of the refrigeration groups decided to tabulate sales dates on the products. The store area was organized by the students and the customers used the reading corner to plan their shopping expedition.

Evaluation. At the end of the session the students had to decide what went well; what went wrong and how they would organize the situation the next time.



Students take responsibility for various tasks at the farm store

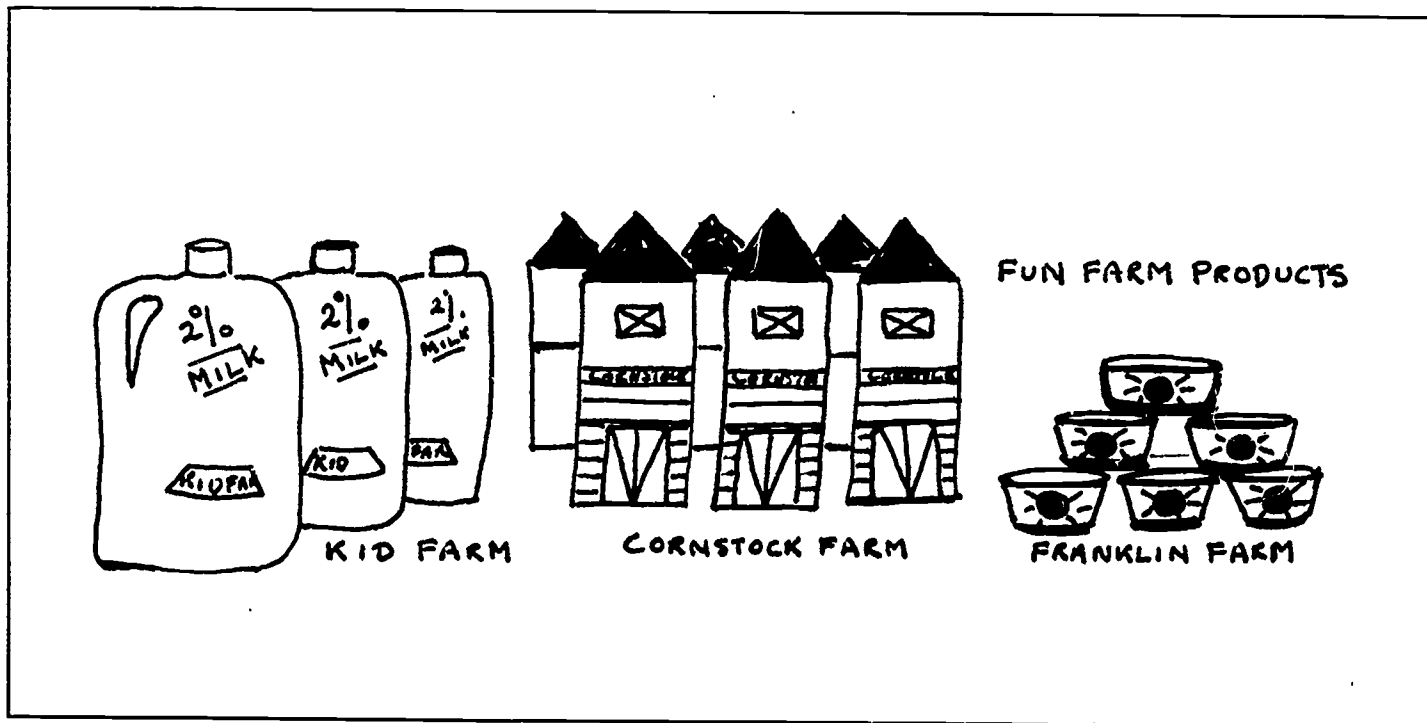

5

DESIGN EDUCATIONAL ACTIVITY

► **Activity based learning. Two examples:**

In this chapter two kinds of activity based learning are described. Both examples involve simple technological and procedural skills in the early years of schooling. The first example demonstrates a style of teaching which develops knowledge of technical skills but gives students limited opportunities to make choices. The second example exemplifies a design educational activity.

Two practical activities for kindergarten and first graders are described. Both involved making puppets.

► **Making a hand puppet**

The usage of the word **craft** to describe a school activity has largely fallen out of fashion, however craft is the technical term for the first type of practical work to be described. A craft activity involves the transmission of knowledge and skills based on tradition. It is dependent on knowledge and understanding of materials, in this instance paper which can be folded, bent or made rigid. In the paper bag puppet activity the student cut around ready prepared templates. The skills involved cutting by drawing around a cardboard template, cutting construction paper with scissors, assembling the pieces with adhesive onto a paper bag to make the shape of a cow's face (some shapes were superimposed over others). The end result was determined by the accuracy of the drawing, cutting and the decisions that the maker had taken as he or she went along. The knowledge and skills to be learned were prescribed before the lesson.

The teacher in this example is like a master crafts person because he or she knows what is to be made and how it will look or work before it is made by the students. The students behave like apprentices and follow the directions of the teacher. This is a mode of imparting technical knowledge and skills which has been passed down for generations. This kind of approach is widely practiced at elementary level to make arrays of fish, teddy bears and animals of all varieties. The individual outcome of a set of work looks remarkably similar. The value of this kind of activity is that each student can be assessed individually and the student has an end product to take home. The teacher can test the acquisition of skills, and control procedural and technical instruction. This method is valuable and necessary in order for students to learn to follow instructions.

► **A design brief approach**

In the second approach the students worked to a design brief:

A design brief is the name given to the formal description of an activity. A design brief has a format which describes a situation. Sometimes this may be a hypothetical situation. It may be a real task within the context of the student's own experience. The brief asks the students to do something related to the situation. This may involve a challenge, a problem to solve or a creative opportunity.



This design brief invited students to respond to an opportunity to:

Design a family of finger puppets for use in the class room to play with and to tell stories.

Students will need to work together in groups of three to four people.

You will need to decide what kind of family to make. Each member of the family should fit onto the fingers of one hand. Materials available are: Various colors of felt fabric, threads, adhesive, needles, buttons.

The subject for the design activity was chosen to develop the concept 'families' which was a learning objective for grade 1 in the county Program of Studies for social studies. Families comprise of: parents, children and relatives (large, small, adult, child); lineage and ancestry (links to past, old, young); groups of people, animals or objects distinguished by com-

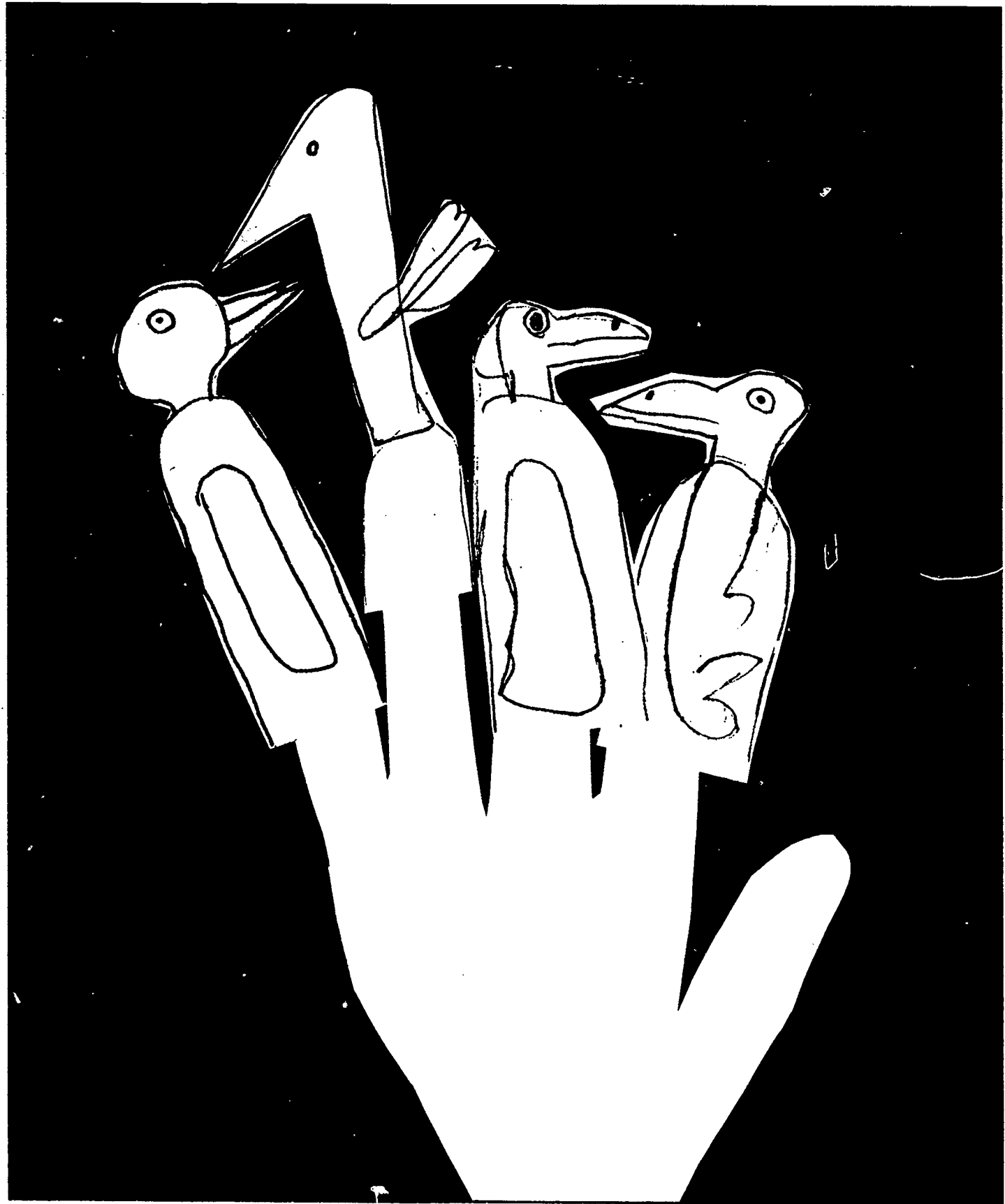

*Families of finger puppets
The individual products within each family had marked similarities—just like families*

mon features (birds have beaks and eyes at the side of the head, cows have horns, cats have whiskers). The focus of the activity was on this last group.

► **The criteria for assessment:**

- work in a cooperative group in accordance with the design brief criteria;
- demonstrate basic understanding of relationships: family grouping, shapes, colors, size; etc.;
- identify needs or opportunities;
- generate a design idea to meet the objective;
- sort and choose material, make own template and cut fabric shapes, join materials appropriately;
- using simple equipment, manipulate, assemble and make an outcome;
- evaluate and modify the solution.

► **Students organized in cooperative groups**

The students were organized into groups of four students. The materials and technique were determined by the teacher, in this instance colored felt fabric so that the students would gain knowledge and skills of cutting and joining felt fabric. The teacher gave instruction on the technical aspects through a 'needs to know basis' when the students were ready for this stage. Each student was responsible for one hand puppet.

First there was the question: 'What is a family?' This elicited discussion about kinds of families, and what they had in common. Some groups decided to make a cat family, others a people family or a bird family. Many details about size shape, color and characteristics were debated. Next was the question of size. What size is a finger? Which finger will you make? Fingers were drawn around, measured and compared. The students worked together to generate their ideas on paper as a form of communication to discuss which plan had the most possibilities. A consensus was met to determine the type of puppet, basic shape and color scheme. The students drew their own template, cut it out, cut out felt and assembled through stitch and gluing. Additional details were added to the products. The students discussed their puppets and tested them. Had they met the criteria that the design brief set? Did the puppets work? Was the stitching or adhesive firm? In some cases there were modifications to be made. The end results from each group were different. The individual members within each family had marked similarities—just like families!

Because some students had no previous experience of stitch the project took a total of two X one hour sessions. This can be justified by the amount of creative action, thinking skills and problem solving that was involved, in addition to traditional craft knowledge, skills and group cooperation.

► **Design activity criteria**

The criteria for a designing activity is discussed in Chapter 1 (principles) and Chapter 6 (assessment). In a contrived classroom situation some of these can be set in the design brief. These are reviewed here:

- responding to an identified or perceived need;
- creating something which did not previously exist, or modifying something;
- communicating thought and action using models and codes (discussion with others, drawings and mock ups);
- attaining an intentional outcome;
- following a coherent and structured course of action which is interactive (the rules of the action were being created by the teacher in order to stimulate a pattern of trying something out, evaluating it, trying another way which is the basis of design methodology);
- taking place over time (the students were involved for two hours of concentrated action);
- being manifested within a system of values (these included technical quality and aesthetic, social and cultural judgments and skills);
- reaching an outcome which was a compromise of the accumulative demands of the activity
(the quality depended on the groups understanding the concept family relationships and their manipulative dexterity);
- justifying the results (Would the puppets stay on the finger? Would other children want to play with them?).

► **Manufacture simulation**

The template craft activity can be turned into a design activity if the process and product are conceived as a design and manufacture simulation. In manufacture the form, shape, color, style and texture are all determined before production. This intended outcome could be stated in a design brief. Thus students could develop awareness and practical application in a collaborative venture.

► **Learning across subject boundaries**

Learning in design educational activity appears to cover the boundaries of several subjects, though so far there is limited research in this field. This activity developed math, technology, social studies and art knowledge and skills. In this activity the learning objectives covered the development of conceptual knowledge about materials and their properties; transformation of shapes of material into a three dimensional form; procedural knowledge about the process of producing a product; technical knowledge about shaping and cutting and joining pliable materials; measurements and judgments of size and relationship to the human body; social

awareness of factors which distinguish families; aesthetic choices about the shape, color of the product.

This knowledge and skill could be a basis for learning about manufacturing in technology education; relationships of size, shape, sets in mathematics; or the development of perception and expression in art.

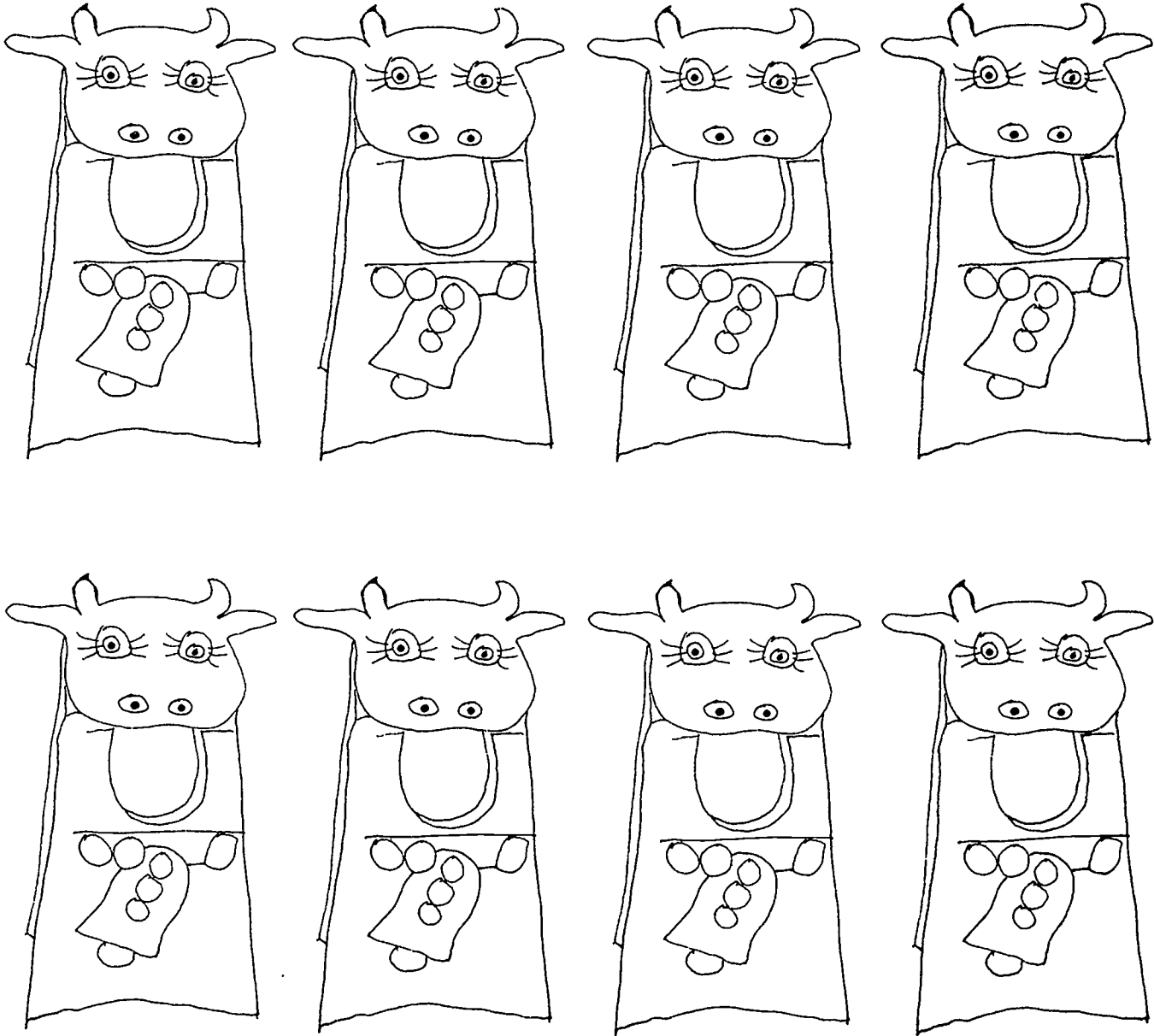

The template craft activity can be turned into a design activity if the process and product are conceived design and manufacture simulation.

6

ASSESSMENT APPROACHES FOR DESIGNING ACTIVITY

Teachers gather information about students in their care to inform themselves and other interested parties of the progress of each child. The teacher is accountable to several people for what students are learning and understanding in his or her classroom. Parents and the community are eager to know what students have achieved in language arts and math in particular because these disciplines are not only important in themselves but are a measure of student's progress in many other curriculum areas. It is upon these fundamental skills that society determines the attainment of individual students. If designing capacity is as basic as literacy and numeracy (see Chapter 1) then it too should be assessed and reported on to the community.

The aim of this chapter is firstly to discuss the need and purpose of assessment for designing activity; second, to outline the principles of formulating methods of assessment for designing activity. When there is no assessment procedure in place for design activity (and technology activity) it sends a message to children, parents and others in the community that the activity is unimportant, or at least not so vital as some other aspects of students' learning and development. It is perhaps because designerly activity is largely a cognitive process, takes place over time and involves the application of a wide range of knowledge and skills from several disciplines of study that activity in this area goes unreported. It does not conform easily to testing procedures because it is largely a qualitative activity, assessment is likely to be subjective and not easy to validate. The inclusion of design activity across the curriculum would help to define learning, maintain relevance to issues of concern to the student and help to refine the process of teaching and assessment.

Assessment is the process by which information and data is collected and organized. It is only an indication of the worth of a student's learning and is open to interpretation. Testing is a form of checking up what has been learned but it is not the same as assessing. Testing is just one way of making an assessment (Harlen 1993).

► *Assessment and evaluation*

Another area of confusion is between making assessments and evaluations. This is important because evaluating is such an important part of the whole process of designing. The evaluative judgment that is made in connection to the data is known as evaluation. Evaluating involves estimating the worth of something and making judgmental choices. Designerly activity involves making constant evaluations.

► *Norm-referencing and criterion referencing*

When comparing the standard between students of the same age or experience the term used is **norm-referencing**. When levels of performance are compared the term used is **criterion referencing**. Comparing students previous performance is known as **pupil referencing**.

A main argument for standardizing tests (in norm-referencing assessment) has been to maintain valid, accurate and reliable data. It is a problem when data only estimates what students know rather than what they understand, and when skills that are reported have little relevance beyond school (Zessoules and Gardner 1991). Perrone (1991) argues that these assessment models do not get 'particularly close to student learning' and do not 'provide teachers with much information of consequence'.

► *The purpose of assessment*

The kinds of assessment that take place in the classroom are aimed to provide:

- **on going information** for teachers which assists them to make decisions about the daily and weekly learning of individual students. This may take the form of anecdotal notes;
- **formative and diagnostic information** to help identify strengths and areas where change may be needed;
- **a summary of achievement of individuals** which gives an overview of individuals at a certain period of time to report to others.

A second group sometimes reflect the politically motivated rather than educational ends of assessment, which are:

- assessment for selection to special programs e.g. magnet schools, gifted and talented programs;
- selection to colleges, universities and the world of work;
- evaluation for monitoring the effectiveness of the schools;
- county, state and national monitoring to review the performance of school systems.

This culture has had a large role in driving assessment. However, educationalists are noting a tide of change taking place in schools. Chittenden (1991) states that: 'The interest in assessment methods that are closer to classroom practice is growing' and that: 'Classrooms are moving from a *testing culture* ----- to an *assessment culture* (Seeley 1994).

► *The increase in alternative modes of assessment*

A National Science Foundation group of curriculum developers report that: 'Research shows that extant achievement tests do not measure the broad range of scientific processes or higher order thinking skills' (Harmon et al 1988) and they argue for a need for alternative assessment methods. Other process based areas such as technology, the arts and designing activity in general have similar problems. The shift in the 1990s has been towards identifying different forms of assessment increasingly referred to as **alternative assessment**. This is good news for technology educators and for assessing design education which must be assessed not only on the outcome of the activity but on the students performance as well. The practical arts have long had their own forms of documenting achievement dating from the 19th century and the the practice of John Dewey and other progressives. However, they will need to explore ways of not only assessing the products of their activity but also the students' performance and development.

Alternative assessment is a general term used to describe any form of assessment that differs from norm-referenced. **Authentic assessment**, a term coined by Wiggins (1989) focuses on students being able to confront 'real world challenges', to see new possibilities, to step back from their work and reflect on it, to build on their own strengths. **Performance assessment** seems to address process activity but also embraces learning outcomes according to Marzano, Pickering and McTighe (1993).

► *Searching for a model for assessing design activity*

Norm-referenced methods of assessment where there is one right way or answer are unsuited to designing activity. Design educational activity needs to be assessed through criterion-referenced and pupil-referenced methods, a model which would place it within the range of authentic and performance based assessment. However, there is by no means any consensus on what a new generation of assessment strategies and instruments will specifically look like (Chittenden 1991). The qualitative and integrative nature of designing activity, the relationship of the processes to the outcome, the interdisciplinary relationships, put design education assessment into a category of its own. Some research of primary design and technology assessment has been undertaken in the United Kingdom by the Assessment of Performance Unit. It might be fair to say that the development of models for design educational assessment is in the design analysis phase of the problem.

► *Assessment as part of the teaching and learning process*

One attitude which has been gaining momentum sees assessment working in tandem with instruction and learning

and not separate from the educational process (Zessoules & Gardner 1991, Marzano et al, 1993 and Sperling 1994). The goal for teachers is to achieve a clearer picture of what students have learned; for the students to have an active role in their own learning; and for information to be related to the parties involved in a meaningful way.

In assessing **designing activity** the outcome of the student activity has to be assessed i.e. the quality of the product. In **design educational activity**, the student performance and other learning benefits have to be determined in addition to the product. There are several questions:

► *1. What information about the student's progress will be reported?*

In the activity: Design a family of finger puppets (previous chapter) the teacher had to evaluate the following criteria:

- Did the students meet the requirements?
- Was it what was intended?
- Was a new / original / inventive idea developed?
- Would it work?
- Would it be useful?

An important aspect to understanding families involved identifying the features they have in common, i.e. birds have beaks, cats have whiskers. The teacher also needed to know what evidence he or she can see of self appraisal, for example:

Was the student able to appraise the task by taking account of the original intention?

► *Group and individual assessment*

As a group of children worked together the teacher may have to make an assessment of the outcome for the whole group. In doing this assessment he or she may also think about the quality of the task and whether it was appropriate. This part of assessment is not dissimilar to evaluating the lesson teaching plans. If the purpose of the assessment is concerned with informing teaching and giving help to students as a group, group assessment can be considered (Harlen 1993 p.158). Through this process the teacher is more likely to have a clear picture of what the students have learned.

► *Design activity assessment criteria*

Designing involves mental and physical process activities. Here is a selection of criteria that might be chosen to assess the puppet task:

- Was the student able to suggest an opportunity or a problem?
- Was the student able to initiate ideas?
- What kind of means of communication did the student use?
- Was there evidence of modeling skills? e.g. drawings,

computers printouts etc.

- ▶ Was the student able to discuss with others what he/she had accomplished?
- ▶ What knowledge and skill of materials was the student able to demonstrate?
- ▶ Was the student able to communicate with others in the group?
- ▶ Did the student need instruction in e.g. cutting, sewing etc.?
- ▶ Was the student able to complete the task?
- ▶ Was the student able to assess their own performance?

Designing activity depends upon other forms of knowledge in order to take action. If designing activity is said to contribute to learning in the wider curriculum it is known as design educational activity (see Chapter 2 for distinction). Therefore the teacher will need to record among his or her criteria what knowledge, concepts, skills and attitudes were intended during the activity. In the puppet task these might include:

- Writing about the puppet family;
- Understanding pairs;
- Learning about scale and size;
- Physical coordination.

Criteria are based on what is reasonable to expect of students at a specific age level. There are many potential criteria and teachers need to consider context, age, and ability of the students and the learning intentions in making a selection. The list should not be too long as too many criteria will make the assessment task become unwieldy.

▶ 2. What methods will be used to collect evidence of learning?

Notebooks, check lists, photographs, audiotape and videotape, diskettes are all ways of collecting information.

Concrete evidence such as a drawing, model, computer printout etc. can be examined after the event. Information about when and how these were produced is also invaluable.

Close observation of the student while they are engaged in activities. This may include their interaction with group members; their conversation with peers and other adults; their ability to handle materials, tools and equipment.

Finding out by asking questions before, during and after an activity is another way of eliciting information.

Checking up: synonymous with testing, can be used for finding out what has been learned.

Keeping track of students' progress can be met effectively when students keep a portfolio or folder record of their activities, a practice long used by artists and designers.

A variety of methods of collecting evidence of design and technology activity should be used. These methods will also be used to collect evidence of other subject knowledge, so a portfolio will hold science, math and language development

as well. Designing activity for example, should not be assessed on the content of the portfolio alone as each item is in itself a product and does not show the procedure involved. As students progress through the school they can be more responsible for their portfolio evidence.

Monitoring students' actions can only be covered a few students at a time. Teachers need to organize a system for observing and note taking similar to observing children's reading progression.

▶ Self evaluation

Some of the more interesting methods for evaluating design and technology activity involve the students in documenting and recording the process of the activity. The teacher is an outside observer, he or she can only record its presence; the students are involved in the action, they are a primary source of information. There are developmental implications in this strategy, but even quite young children can account for what they are doing and what they might do in the future. Rogers and Clare (1994) have been conducting a research project based on this method with elementary age students. An example of this strategy for 5-6 year old emergent writers:

	My ideas are:	Today:	
Statement of intention, need, desire.	_____		
	I am going to:		The child photographs activity. Draws. Makes a statement.
Plan	_____		

The children worked on the topic 'toys'. Each child has a record sheet:

They believe this approach: is pro-active;
 increases motivation;
 makes the process more evident;
 directs thinking;
 transforms problems to challenges;
 makes communication more effective;
 promotes independent work;
 is a structural approach;
 has built in progression;
 supports reflection;
 is a powerful aid to assessment of process.

Models which involve students in self assessment are very positive. The process of assessment enables students to describe what they have been doing and to develop value judgment skills. This process can be extended to group activity and to peer review. The major drawback with the model de-

scribed is that it could become a formula. It is useful for certain kinds of work, but should be used with other forms of assessment.

► **Peer review**

As students progress through the school, individual students can take more responsibility for reviewing their own progress in relation to that of their peers. In a design educational activity such as the finger puppets described in the previous chapter groups of students can be actively involved in assessing the outcomes of the other groups by comparing each set to a list of criteria:

Is this a family? If not, why not?

Is there a puppet for each finger? Do they fit?

Do you like them? Which set does your group prefer?

An element of competition may be injected if desired. Similarly, peers can review the outcome of individual student projects, by comparing and evaluating the contents of students' portfolios. This encourages students to share ideas and skills.

► **3. How will judgments be made?**

A single method of evaluation is inadvisable for the complexity of designing activity. Teachers will have accumulated a variety of evidence about what the students know, understand and can do. They need to establish a policy for judging the outcome and performance of student actions to compare with learning expectations, individual attainment and to show progress. A good analytical narrative is time consuming to prepare but is one method of commenting on

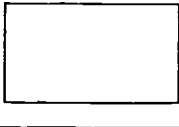
PROJECT: Change		Student Name: Bill Class: Grade 1 ; Group: Green
Marking Period	Holistic Mark	Overall student worked
Week 1	O (G) S N	convergent and committed
2	(G) G S N	inquisitive, resourceful
3	O (G) S N	divergent and innovative
Photograph of student activity		Summative comment on the whole activity
		<p>Bill responded well to the design brief. He has an inquiring mind and explored several ideas creatively in developing the design task. In addition, he showed that he could work cooperatively with other students.</p>
<p>Teachers comment from observation</p>		
<p>O Outstanding, G Good, S Satisfactory, N Needs Improvement</p>		

overall student attainment. There are two important aspects to be judged: the outcomes/product and the performance/process. Guskey (1994) points out that grading and reporting methods remain inherently subjective while holistic scoring procedures tend to have a greater reliability than analytic procedures. Holistic scoring procedures have been used widely in art and design activity. The Assessment of Performance Unit (1992) used a holistic method to judge attainment outcomes in design and technology.

Performance based activity can be tabulated and ranked as follows and if necessary a rubric for scoring can be set to match the statement.

STUDENT NAME: Chris	YEAR: Grade 1	GROUP: Orange	Level of Achievement	Classified Agency
IDENTIFYING NEEDS AND OPERATIONAL SYSTEMS that the student can describe what he or she has realized, suggest an opportunity or a problem, presented an imaginary situation	not yet	developing	achieving	Classified mark: 0-10
DEVELOPING A DESIGN PROPOSAL. Evidence that the student can: choose ideas, working what he or she might do, select ideas and give reasons for his or her choice	not yet	developing	achieving	Classified mark: 0-10
PLANNING AND MAKING. Evidence that the student can: communicate plans to others, apply knowledge and skills of design and make personal creative activity and progress the task	not yet	developing	achieving	Classified mark: 0-10
EVALUATING. Evidence that the student can: discuss with others what has been accomplished, describe what he or she thought was successful and unsuccessful, evaluate the task by taking account of the original intention	not yet	developing	achieving	Classified mark: 0-10

Sperling (1994) reports on a way of recording students' performance which has been developed by the Ann Arbor school district, Michigan. This method reveals students' learning and this progress is reported to parents. It may be used as an alternative method for reporting student progression in designing activity.

► **4. How will it be reported?**

The teacher's activity in the classroom has to be accountable and communicated to others in a way that is easily understood and not so abstract that it is difficult to decipher. Letter grades, for example, are not recommended for this purpose. Information provided for parents and other interested parties needs to be clear and succinct. There should be a statement about the teaching aim/objectives followed by a mark or statement of the student's overall achievement. A similar indication of progress should be stated by a mark or narrative statement. The relationship between teacher planning, student's activity and assessment needs to be evident.

REPORT TO PARENTS	STUDENT NAME:	GRADE: 1	
DE SIGNING	Feb	Other	Spring
Creating a design proposal			
making ideas			
planning and construction			
Response to design activity			
marks provided each period			
marks on the task			
<p>EEF = Not yet, DEV = Developing, AC = Achieving</p>			

A progress model: Report to parents

SCIENCE, TECHNOLOGY AND DESIGN: learning activity in the context of a theme

A thematic approach to learning has been selected to illustrate how designing activity is distinctive and yet similar to other process learning activities in science and technology education. It shows how a theme can be used to develop learning in science, technology and social studies. The principles of this model are relevant to all elementary grades.

► A theme

A theme is a cluster of ideas grouped together on related and inter-related subjects. It can be a continuously evolving and developing thread which may be either one-directional or multidirectional. The theme approach is open ended, one can continuously move outwards and inwards making discoveries along the route, which may however lead from the original subject.

Themes can be composed of topics and projects. Each part of the theme is self contained and connected and need have no time limiting factor. A theme can be developed by a group, a whole grade or even a whole school. It can last for a month, a semester, even a year.

► The theme: CHANGE

This subject for the theme was selected by the teachers involved as one that would readily incorporate the knowledge and skills that were indicated in the county Programs of Study for Grade 1. The concept of change is embedded in the processes and systems of our environment. The teachers agreed that it would be important to develop student's understanding about changes that take place in the natural world and for students to learn that they can control aspects of their own physical world by acting upon their surroundings.

► Students prior conceptions of 'Change'

The first task was to find out what the students understood about the concept 'Change'. Stories about change that involved fantasy were read to the students to see what pre-conception they had about change before planning any activities. They were asked: what changes took place in *Cinderella*² and what happened *When the Wind Blows*?³ What different kind of environment did the children encounter in *The Lion the Witch and the Wardrobe*?⁴

²Galdone, Paul. (1985). New York: McGraw-Hill.

³Briggs, Raymond (1982) New York: Schochen Books

⁴Lewis, C.S. (1957) from *The Chronicles of Narnia*, New York: Macmillan

The students had little problem identifying the obvious physical changes to pumpkin, mice, lizards, dresses, time, displacement of objects, and environmental surroundings. They made interesting social observations about changes in the family with the introduction of a stepmother and peoples changes in mood and attitude to each other. This opened a rich verbal discussion with the whole class about the kinds of changes they have experienced in their lives. It gave an indication of what children know of technological procedures and systems.

The responses included such observations of lifes processes as:

- when you eat food it changes inside your body;
- cereal starts out as a plant, it has to be cut to make it into cereal;
- when people come to stay in your house kids have to change beds;
- hair color can be changed;
- when there is late opening (because of bad weather) schools have to change the timetable.

► Students' notions of reality and fantasy

A student's reality at the age of seven years seems to coexist happily with fantasy. Children can imagine all sorts of wonderful uses for a pumpkin and think about it as the ingredient of a delicious pie. The gradual development towards realism also has to be tempered with keeping students imagination alive. Design and technology as well as science are dependent on exercising the human gifts of imagination and inspired thought. One of the developmental passages that children have to pass through is to distinguish between what might be feasible to create, build, organize and what is not. It is useful to keep this opportunity to imagine, create and speculate, while providing a framework of knowledge and skill that works. By the time students reach the higher grades they will differentiate between fantasy and reality.

► Organization

The two first grade classes explored this theme over a period of six weeks. Each group of eight students had a one hour session each week.

The following topics related to **Change** emerged as a result of the brainstorm session:

FORM—How can we change one shape into another shape or form (seed to food; fiber to paper etc.)? How can we alter the appearance of some-



Designing paper into many forms

thing? How can we join one part or material to another and make something different? (Construction kits, paper making etc.).

MOVEMENT—*How can we change the position of something; extend the capability of our bodies; transporting things; moving things. Investigate technology which helps people to change things (e.g. exploring wheels, mechanisms).*

PROCESS AND PRODUCTION—*How do we gather and record data about change? How do we change the system? (e.g. How do we use non-verbal means of recording, drawing, graphs etc. How can we use computers to store and retrieve data).*

Each of these topics is a conceptual theme in its own right and may be developed as an integrative subject of study. The focus was on 'change' within these topics. Each topic leads to understanding of a conceptual body of knowledge about materials and energy. The title is also a way for students to think about the concept of procedure and processes and what is involved.

The topics identified were selected in order to develop **scientific, technological and design activity**. A selection of mini projects have been selected for discussion which were developed out of the theme: some were focused on science, some on technology, while others were specifically concerned with designing.

Science, technology and design activities often appear very similar in educational practice. The activities are selected in order to explain how these disciplines have different goals. The student activity involved inquiry into the natural and the physical world. Science is concerned with explaining and understanding the natural world and universe; technology takes action using scientific and other kinds of knowledge in solving human needs and problems; while design focuses on the human made world and what might be created in future.

A scientific approach

In the context of the theme 'Change' scientific procedural skills were developed when the students witnessed the growth of seeds (sunflower) and compared them to bulbs. The aim was to understand the concept of growth and to investigate the changes that take place. Concepts related to 'Form', 'Process and Production' were discussed and developed during the activity. The process skills involved were:

- observing ecological change of sunflower seed and bulbs;
- hypothesizing about what conditions the seeds and plants would need;
- predicting where the growing points would be, speculating about process of growth, speculating about process of growth, which examples would grow first;

- investigating the planted seeds at weekly intervals, comparing seed with bulbs;
- drawing conclusions about which conditions were successful;
- communicating the results of the experiments.

The students worked in individual, paired or in a group working situations. They gathered and organized data, and recorded their information through observational drawing, measurement and writing. They used computers to store data information.

During the course of the seed observation some technological questions arose: which containers were best for planting seedlings and why? Why do some seeds grow and others wither away? What method is the best for watering seeds? One of the problems about this experiment was how to water the seeds. Here was an opportunity for extension activities which would develop designerly thinking arising from need and the application of technological systems. What watering device works best? How can a watering system be devised? How can we design the best system for taking turns to water the plants?

Similar approaches were used when students explored aspects of physical science, such as movement and energy through observing and investigating wheels.

The students also explored the concept 'change' through manipulating images and learning that they could use computers to control change. For example, changes in the season and the weather were conveyed through Kid Pix (see illustration). They also used construction kits, for example: Gearios Kit (GEA 100T), Tac Tic (TAC100T) available from Modern Schools Supplies and LEGO DACTA ® sets to control changes in their own physical world by acting upon their surroundings.



Changes in the season and the weather are conveyed through Kid Pix

A technological systems approach

In this activity a group of students were given an opportunity to experience changes in form through their own action. This was exemplified in an activity which involved recycling paper through a system of INPUT ----- PROCESS ----- OUTPUT. The materials were organized through a system which transformed the physical matter into something else. Some systems approaches require ENERGY and a method of CONTROL. This activity used water and an electrically powered mixer to supply energy and a frame (deckle) to sort and control the small fibers. Three colors of waste construction paper were available: yellow, blue and red. The students were invited to select two colors to begin with. One student described the stages of changing scraps of yellow paper back into a piece of paper in 8 steps:

Student example.

Recycling Paper

- 1. We tore up some waste paper***
- 2. We put it in the mixer***
- 3. We put the paper in a bucket of water***
- 4. Then we placed the deckle in the water bucket***
- 5. Then put the paper pulp in a bowl***
- 6. Put the deckle into the water and take it out***
- 7. Then put the deckle on a piece of paper and blot it with a Kleenex***
- 8. Take the deckle off very carefully.***

This process was repeated by adding pieces of the second and a third color to the pulverizer and three more pieces were produced. Other students recorded the color changes:

yellow scraps → yellow paper = no change in color
 yellow + red scraps = light orange paper
 yellow + more red = dark orange paper
 yellow + red and blue = orangy brown paper

Another student wrote captions to the result of the experiments on a computer: e.g. This is a small frame like a window screen. It is called a deckle. We put the deckle into the bowl and collected all the bits of paper. The procedural skills involved:

- processing one material into another;
- developing manipulative skills using tools;
- making changes and modifications to the product;
- recording the process system through words and pictures and using a computer to organize data;

This activity could have been presented as an investigative science activity following the scientific procedures referred to above. In this context, it was not developed solely to gain scientific understanding. The focus was on understanding a

technical process and on solving the problem of recycling waste paper. After completing the task: a critical thinking and problem-solving approach to this context would need to ask:

- What can a small shape of paper be used for?
- How could a large piece of paper be made?
- Can the texture be altered?
- How could the equipment be modified and improved?

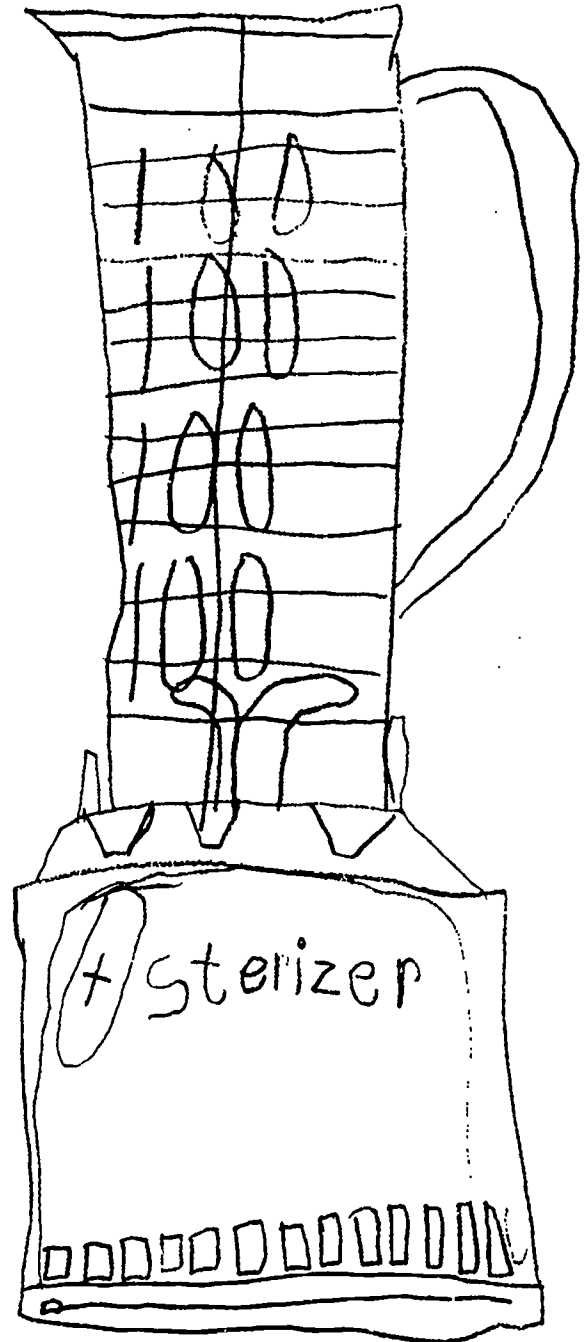

► Science and Technology Education

Science and technology are closely related. Science activity differs somewhat from technology. Science is about knowing and understanding what is and about making informed judgments as to why things are in the natural world. It concerns making predictions about what is likely to happen in given circumstances. Technology (*from Greek, technologia*, systematic treatment) is the i) science or study of the practical or industrial sciences etc.; ii) the term used in science etc. technical terminology; iii) applied science; iv) a method, process etc. for handling a specific technical problem; v) the system by which a society provides its members with those things needed or desired. (Webster's Dictionary)

Whereas science is about understanding the world, technology is about taking action and knowing how to take action upon our physical surroundings. In order to make things happen in a desired way technology draws its knowledge from the sciences, from its own knowledge and from design knowledge. The National Science Education Standards (Draft Nov. 1994) include technology as a process parallel to science as inquiry. As an education subject technology needs to address the social and cultural aspects of taking action and making changes in the physical world. There are several definitions of technology education. This one initiated by members of the International Technology Education Association is instrumental and content based and lacks a social, cultural and economic dimension.:

Technology Education: an educational program that helps people develop an understanding and competence in designing, producing, and using technology products and systems. (Wright, Israel and Lauda. 1993)

It seems to be unclear whether or not technology education should be solely instrumental and content based (as this definition appears to suggest), or whether it should have an additional social, cultural and economic dimension. The possibility of integrating the discipline of design within the technology subject area may clarify the direction technology education may take. An ITEA definition embodies three elements of designing: cognitive processes, creativity, concern for the future. It does not incorporate developing technology in response to needs and opportunities, nor does it begin to address social values.

Technology Education is the school discipline for the study of the application of knowledge, creativity, and resources to solve problems and extend human potential. (ITEA 1988)

A more serious problem for technology educators is the confusion between developing educational (instructional) technology and technology education which has inhibited the full development of technology education across the curriculum and divorced the activity from cultural matters (see

Layton 1993, and Scaife and Wellington 1993 for further comparison between Science and Technology Education).

► Problem-solving approaches

An approach to technology education has been through problem-solving. A series of problem-solving steps are linked by feedback so that the problem and the solution are interactive. This has provided schools with a process based model which is distinctive from other school activities.

As demonstrated in the paper making context, when a critical thinking stance is taken, a series of problems arise in the course of the activity. Technological activity is in itself about problem-solving. When problems can be measured by some quantifiable test there is likely to be a **viable solution**. Once social, cultural, economic, aesthetic, ethical and ecological and technically qualitative decisions are involved the activity becomes associated with designing. **Design problems involve more than one viable solution.** All the technical

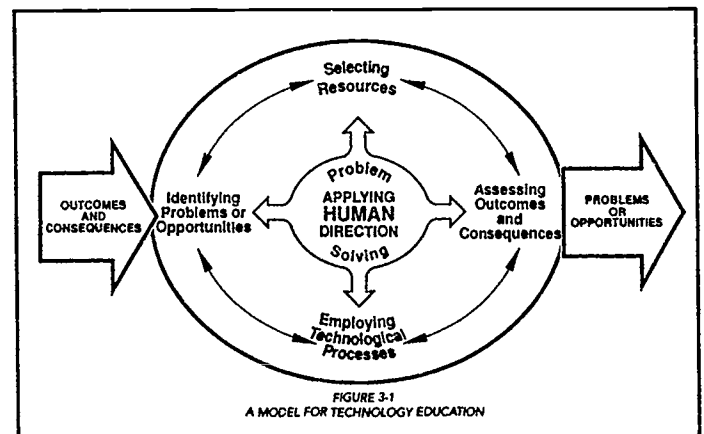

problem-solving is surrounded however, by qualitative questions of value. Therefore designing should have a role in technological problem-solving.

Some problem-solving approaches are not concerned with designing, particularly when the problem is prescribed and it is a thinly disguised solution. Other approaches set by teachers are not problems at all, for example:

- the teacher has a ready made solution in mind against which the student outcomes are judged;
- the problem is set to lead to predetermined tools, materials or skills;
- the problem is irrelevant to the students experience, interest, world.

The paper making activity was technical, practical, experiential and quantitative and started with the excess of waste paper (a problem). In some senses it typified what is referred to as 'hands on' learning, an expression which has become something of a cliché and is sometimes insufficiently 'minds on'. The technical problem-solving and design problem-solving stances were not introduced initially as it was important

that the students were involved in the definition and selection of problems.

The real opportunity for creating a design educational activity was present when the students started to generate their own ideas about how and for what they might use the paper pulping equipment. They soon found out that they did not have to make flat shapes but could manipulate the shape into 3D form. Some of the students began to notice things around the classroom that had been created by this manufacturing process: egg cartons, seed trays etc.

A design processes approach

Design activity is more than the application of procedural knowledge, or a means of organizing information. In education, Perkins (1984, & 1982) believes that the development of knowledge should be encouraged as the product of creative effort rather than by the conventional mode whereby knowledge is given (through instruction). He argues that pieces of knowledge are designs shaped by human invention; he uses the metaphor 'Knowledge as Design' to unify the range of human productive activities under a common framework.

Designing has its own form of knowing about the world, through its use of cognitive intelligence (Cross 1982). Purely scientific and technological activity operates by a different system than designing activity as illustrated above (and can be compared with the design educational activity discussed in Chapter 5). The creative and organizational thinking processes of designing may also be introduced into scientific or technological activity.

It is very misleading to characterize designing activity in terms of a singular linear process. No cyclical model can fully explain the phenomena of a designing activity. As discussed in a previous section **many people equate the process of designing with problem-solving. This is a misnomer.** Designing involves many kinds of thinking which do not necessarily have a linear process base.

The following characteristics distinguish designing:

- **Designing involves intentional activity and a result that is expedient**

A design activity has to be intentional, when the task is complete it must be evaluated in terms of whether it fulfilled the intention. In this sense designing can be expressed as a cyclical process but unlike problem-solving there is no right answer, just one that is the most expedient.

- **Designing is an inventive response to need and opportunity**

Every person who designs makes an individual response to their surroundings and the constraints of designing in an individual way. There is no set pattern to starting a designing activity or to carrying it out. One person may start

by exploring material, another by evaluating a mechanism, while a third may sketch an idea on paper.

- **Designing is purposeful and productive**

Designing inevitably involves other people, as clients, customers, sponsors, managers, fellow workers. Decisions are seldom made without the constraint of other peoples attitudes and opinions. Design is created for people. The purpose and decision making takes place within a system of human values, there are several layers of qualitative decision making (referred to in Chapters 1 and 2).

- **Designing activity is an integrative whole**

What seems to be apparent about designing activity is that there are several procedures taking place simultaneously and they are integrative to the whole activity. A person who is designing will use knowledge and skills from many disciplines. Designing supports learning in Technology Education and has become an integral part of several curriculum frameworks. Designing is not bound to any individual subject area.

► ***Levels, procedures and stages in designing***

The processes of designing are somewhat difficult to describe. It does help, however, to have some guidance as to what these processes are as benchmarks for stages in the whole process. (see Chapter 9 for design processes in operation).

There seems to be at least three kinds of processes which are operational:

- 1. There are the decisions about the project itself, what it is and who it is for, and why;** it has a cyclical element as the outcome must meet the project intention.
- 2. There is the procedural aspect, whereby the anticipated tasks are set into a time frame;** it can be a logical order governed by a time frame constraint. Except there will be some back tracking when plans do not work to order.
- 3. There is the designerly thinking level which is divided into many complex subdivisions (thinking processes).** It is likely that the order of action will involve quite divergent kinds of thinking as well as convergent ones on the way to achieving a task.

These thinking processes include:

imaging and speculating (creating ideas in the mind and thinking about what might be);

modeling and communicating (exploring ideas using some of the methods discussed in Chapter 3);

investigating and analyzing (brainstorming, researching data);

developing and synthesizing ideas (generating design proposals);

making and producing (working through design briefs, realizing ideas);

appraising and evaluating (problem solving, critical thinking, judgments, describing and reporting).

Sometimes the designing process is presented to students in four stages: e.g. investigating; inventing; implementing; evaluating and communicating an outcome. While this can provide a framework for action, care needs to be taken it does not become a rigid formula. There is no one direction or order of action in the process of designing as some designing models suggest. **Models which specify 'identification of need' as a commencement are ideologies. In reality, there has to be some exploration, speculation and reflection beforehand.** All of these processes are informed in response to individual attitudes and values. There may also be **other procedural dynamics involving social and interpersonal skills** which drive towards the design goal.

The essential element of designing is its creative contribution to the material world. Archer (1984) sees the overall process as a creative sandwich with three kinds of layers (phases): analysis, creative and executive. The creative action is always in the middle. This is a neat image but might

be quite incorrect with regard to children. Archer was writing about adult professional designers. Again we do not know enough about defining the creative potential of young children. The dilemma for teachers is the creation of teaching models that are suitable for student, so many of the existing models are versions of adult designing activity. This point is pertinent when considering appropriate curricula for elementary students.

► **Design Technology**

Some elementary schools have developed programs which develop technology understanding through process design activities. The practical based learning focuses on exploring and understanding materials and mechanisms largely through creating artifacts. Dunn and Larsen (1990) offer teachers some sound practical ideas for developing engineering skills with elementary students using this model. While the design technology model has potential for enhancing learning in the physical sciences and in technology, the development of designerly activity is not fully explored.

DESIGN SKILLS

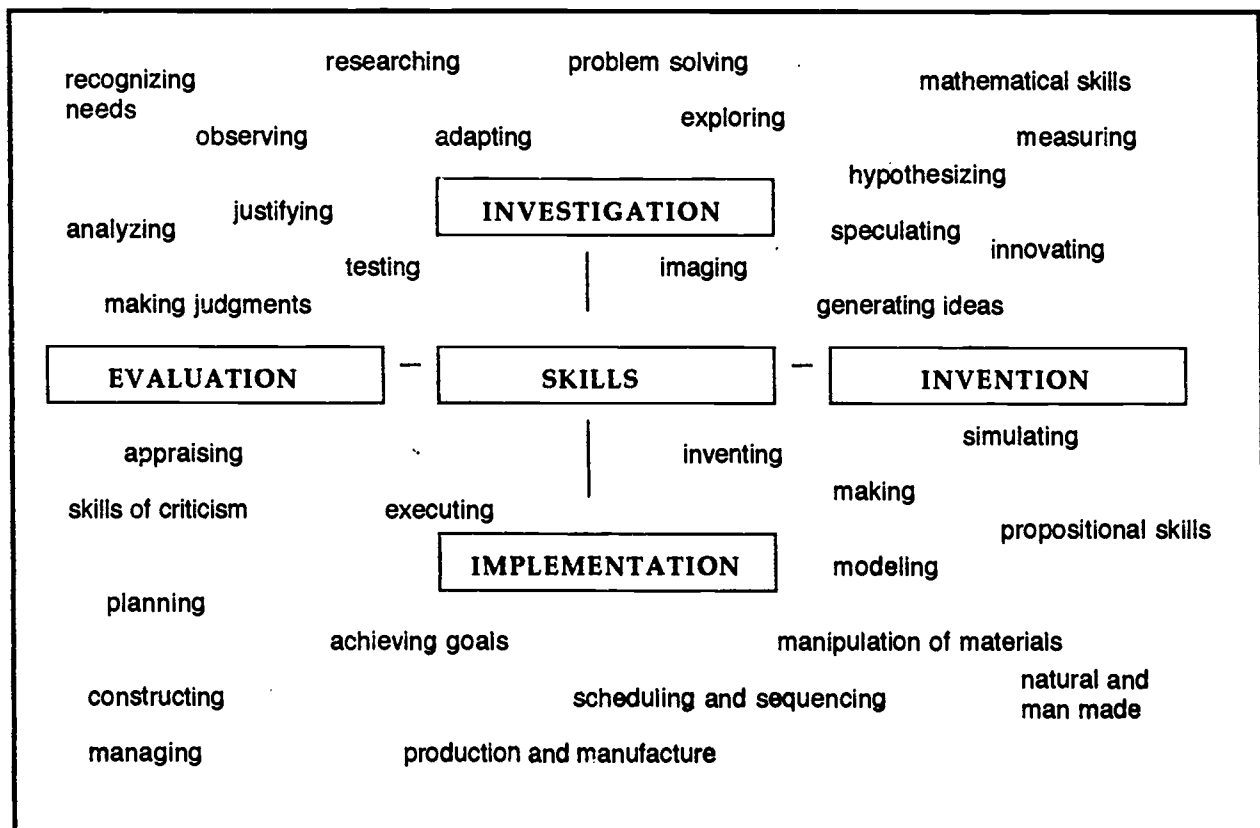



In design education activity students need the teacher to interact with them as they explore and create ideas.

8

THE ROLE OF THE TEACHER

In Chapter 1 it was suggested that the purpose of school is to promote the full development of children's concepts, knowledge and skills as well as responsible attitudes and values. The teacher has a primary role in developing a coherent program in school to enable individual students to reach their potential. This chapter examines practice and attitudes to teaching and learning and sets out some strategies for effectively developing children's designing capacity.

► **Teaching, learning and assessment: an interrelated whole**

Changes in the nature of education goals which include both academic and non academic competencies (see 1991 Scans Report for America 2000) are having an effect on assessment reform and attitudes to teaching and learning in the schools. These goals involve the development of creative thinking, decision making and problem-solving, seeing things in the mind's eye, knowing how to learn, reasoning and the development of personal qualities (page xviii of Report), goals which are outside traditional subject content disciplines. As shown throughout this text, design educational activity directly contributes to these educational goals.

The behavioral learning theories which led to norm-referencing assessment have given way to a conception of learning and teaching based on cognitive psychology according to Shephard (1989). This has heralded a trend towards seeing teaching, learning, assessment and indeed research, as a whole rather than separate entities. It does however have implications for teachers, their role in the classroom and their methods of instruction.

► **Attitudes in approaches to learning**

The idea that teachers view the curriculum specification as a means of feeding their own personal development and bettering their teaching was outlined by Stenhouse (1975) who saw the ideal role model of the teacher as a learner. Three overarching curriculum organizational categories described by Miller and Seller (1985) are transmission, transaction and transformation. In transmissional approaches to learning the teacher controls knowledge. Learning is through step by step approaches and curricula are subject/content centered. This approach, based on Skinnerian behaviorist theory does not foster designerly thinking, independent learning and decision making. Hutchinson and Hutchinson (1991) cite industrial arts programs as examples of this view. They consider that the transactional method best describes the development of the problem-solving, design oriented technology education approach which is prevalent in technology education programs. The emphasis is on the process of student's learning and the interaction between the teacher and the learner. A learning process orientation is typical of the transactionist approach.

This theory subscribes to the view of developmental psychologists such as Piaget and Kolberg that learning is developmental. This approach is also based on a belief that education has a role to play in the development of society whereas transmissionist are concerned with maintaining the status quo.

Transformationists, on the other hand, have a more holistic view of education which is deeply rooted in issues of equity and social justice. A transformist approach to design and technology would emphasise the impact of design activity and technology on individuals and on society and recognize their inter relatedness. This trend towards reconceptualizing ways of describing and understanding the curriculum and the processes of education is a more radical development. What happens in the classroom depends on whether teachers see the curriculum as a whole or as syllabi that have to be covered.

► **Curriculum planning for design activity**

Design education activity can be developed and evaluated through general planning procedures. Teachers need to have a clear view of their curriculum intentions in terms of what they will expect students to know, understand and do:

1. **What kind of learning is intended? What is the purpose of the proposed activity? Will the learning goals involve scientific, technological or designing experience for instance?**
2. **What kind of conceptual understanding do students have and what are they expected to develop? Children already have some knowledge (and some theories too). Therefore what are the objectives of the task?**
3. **What knowledge, skills, concepts and values should the student bring to the task? Design activity requires knowledge and skills for example from several disciplines. These need to be specified.**
4. **What knowledge, skills, concepts and values can be developed through the task? How will the activity enhance learning across the curriculum?**

Teachers would need to create a learning environment based on a foundation which:

- develops perceptual awareness, stimulates student's natural curiosity and instincts and sets the ground for the development of a positive attitude towards learning;
- helps students to build upon prior knowledge and relates new knowledge to previous experience;

- gives students an opportunity for real involvement in what they do, helps them to make connections within a conceptual framework;
- contrive learning tasks that are meaningful, related to the age level and interest of the students in which they are involved and allowed to take responsibility

► **Contriving a designing and learning environment**

Teaching approaches that foster designerly thinking can commence in the pre-school setting. A lead teacher and an assistant provide a teaching and learning environment on three consecutive days for a class of eleven children. This example describes the creation of a play situation that was contrived in school:

Day 1. The materials available in the school setting were: 6x12x15 inch cardboard boxes were taped securely to make building blocks; LEGO DACTA® and DUPLO® bricks were also available. The blocks were stacked on the floor and the DUPLO bricks available in a box nearby. The teacher observed:

One boy built towering cars with DUPLO bricks during most of the 40 mins. free play time. Two boys repeatedly built and knocked down towers of box blocks. (After teacher intervention) they began to build more calmly, and were joined by several girls. Eventually they built an arch entrance to the rain forest (reading corner). The arch became almost magical: when they crawled through it they were transformed into princes and princesses of the rain forest. This fantasy continued for the rest of the play.

Day 2. Same materials plus some LEGO® bricks. This time the teacher introduced the activity by asking: how would you get across a river in the rain forest? She showed pictures of rope and pole bridges and suspension bridges and told stories to go with them. After circle they made a river in an open space of floor by taping blue paper to the floor. She observed:

Several girls immediately drew fish and crocodiles in the river. Then they took wooden blocks off an adjacent shelf and built a functional bridge across the river. They then proceeded to decorate it with odd shaped blocks until it evolved into a sort of tower. Several boys built vehicles with LEGO bricks. One finally had his car float across the river. One boy who often plays alone, built a tower with the box blocks. He then moved to a different area but returned each time someone knocked his tower down. Normally he would act hostile in this situation, but he remained calm as he rebuilt the tower and reminded others it was his.

Day 3. Same materials, similar introduction. The teacher observed:

Several girls covered the entire river with box blocks. Later one tried to make a more traditional bridge with them. Several boys built a campsite with the LEGO bricks.

One began to build a cantilever bridge with DUPLO® bricks (with help from the assistant teacher, but it quickly evolved into a zoo with a garden for the giraffe.

In this scenario the teacher has created an environment where the children start to learn about construction materials and construction through play in the school context. The teacher stimulated a learning scenario and developed and supported the activity without directing it. The teacher and the assistant were facilitators. The children were encouraged to think about needs and how they will set about a task, some are beginning to respond cooperatively. A foundation has been laid by the teacher for design education activity. The principle learning objectives for this activity were scientific. This observation shows how within the short period of time students can build upon their prior knowledge and experience.

This scenario also shows how knowledge and skill are introduced to students in the course of a procedural task. Mc. Cormick (1993) highlights the dilemma for teachers of when to introduce knowledge and skills. He points out (as in this case) that students do not always have the scientific and technical knowledge required to carry out the activity adequately. When taught at the relevant level on a 'needs to know' basis students absorb the understanding of knowledge learned in a meaningful context. Further up the school, design briefs are presented to students sometimes which assume that students already have a level of knowledge. Teachers need to be aware of this when planning activities. Design activities can be developed in many ways with a variety of knowledge and skills. Design activities are culminated by making choices from several potential solutions.

► **Making a start**

A major obstacle in the development of designerly approaches to learning is managing this kind of activity in school. In the scenario described there were two adults and eleven children. Generally teachers have upwards of 24 students per class and from Grade 1 onwards and no regular helpers. Taking a practical or role play activity as described involves risk whenever the teacher is not controlling all the action, because the outcome is uncertain. Having insufficient space, concern about noise level, lack of knowledge and skill, anxiety about basic curricula subjects are all reasons cited by teachers for not developing practical based learning in their classrooms.

Many general teachers in elementary schools have little training or experience in dealing with practical based learning situations such as those delivered by, for example, art specialists. Organizing a variety of materials and equipment; managing a large class; dividing and sub-dividing tasks and

activities; facilitating the learning while the class is in progress are skills that have to be acquired. Some suggestions are:

- **team with a fellow teacher, one takes the larger portion of the class while the other has a smaller group;**
- **have an activities corner, or part of the room set aside where a group of 6–8 children can engage in practical work while the remainder of the class carry out less demanding activity;**
- **develop designing activity on a day when you can rely on a teaching assistant and/or parental support;**
- **wait until some students are out for a specialist lesson and take the remaining portion of the class, give the group that were out an opportunity on another occasion.**

► **Teaching and learning styles**

Designing requires the use of several kinds of intelligence as already discussed on page 21. Students have different learning styles and teachers have to be aware of these learning differences. As teachers move through the cycle of learning his or her role has to change from motivator, information giver, facilitator, resource to evaluator. The approaches to learning: transmissional, transactional and transformational all need to be utilized in the development of a design task. Students will need the teacher to interact with them through discussion and brainstorming and as they explore, and create ideas. Teachers will need to impart relevant knowledge and experience for the student activities; give information, help structure and organize their activity. Teachers and students need to retain evidence of the activity for review and evaluation.

► **Fostering design activity in the classroom**

There are several ways that teachers can encourage design activity:

- encourage children to think about the past as a way of focusing on the present and ask—why are things the way they are today? Build up children's visual memory of objects and physical phenomena as well as words. Use actual objects, photographs and video for this purpose. Show students that the world has changed and it will change in the future;
- foster caring attitudes and understanding of the needs and wants of people in their surroundings;
- value originality, creative and unusual ideas even when they are impractical, allow exploration and discovery without dampening the idea by saying it would be impossible;
- encourage activity with a variety of materials, allow them to be used in an experimental way and challenge the students to think;

- value and develop students' ability to communicate through non-verbal means, encourage wider practice in class of drawing both with and without a computer;
- stimulate critical thinking by asking questions, use neutral, open-ended questions and allow the students to explore propositions: What do you think might happen if.....? How could we make.....? Avoid giving answers and making judgments;
- accept diversity of ideas and choices, each individual responds to their own culture, structure decision-making, compromise, and reconciliation into activity;
- create an environment where everyone feels comfortable about contributing, and that the state of 'not knowing is acceptable'. Teachers do not have all the answers but need to be able to suggest ideas about where to obtain the information;
- help students to overcome disappointments when their work does not go as planned, celebrate success, encourage and support them to persevere;
- allow time for each stage of an activity to unfold. Give students a chance to think reflectively and return to the activity;
- explore patterns of class organization that will work for your class. The management pattern will vary according to the task, encourage cooperation and collaboration and sometimes competition. The examples of management given in the text, often start with a class or group discussion, division into small groups, evaluation with the whole class;
- allow students to take responsibility for their own actions, both as individuals and as a group, develop their own awareness and understanding of their designing activity.

These strategies are compatible with 14 characteristics of intelligent behavior that Costa (1991) suggests teachers and parents should strive to achieve. The focus of this text is, however, the development of thinking strategies as they relate to designing. For a broad discussion of developing thinking in the classroom, teachers may refer to 'Developing Minds' edited by Costa (1991).

► **Evaluating your own performance**

Developing design educational activity is a challenging proposition. It helps if you assess your own performance because in many ways you are engaging in a designing activity. Did you allow for creative modes of thinking to develop? How far did this activity characterize a designing and learning experience? What kind of teaching and learning styles did you employ? How could it have been better? What will you try to do next time? By making a small start you can build on success.

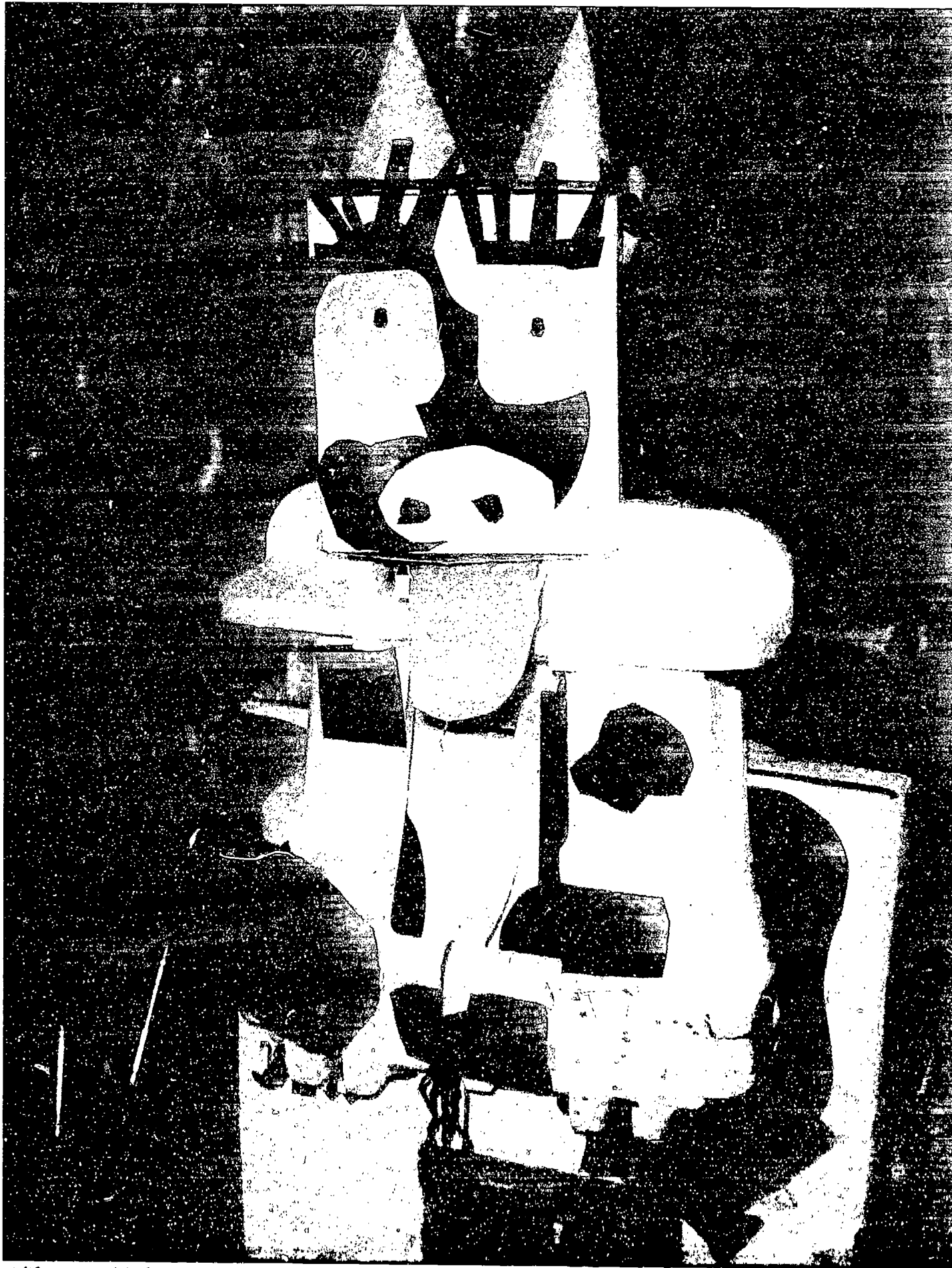

A life size model of a cow was the product of whole class activity (Kindergarten)

9

MANAGING A DESIGN PROJECT

In this chapter the correlation between managing a project and design activity is identified in the context of several examples of student and teacher activity. The management and organization of design activity in the classroom is discussed.

A project approach

A set task for design activity or design educational purpose is called a project, this is introduced to students through a design brief. The project method has a clear objective: it has a set task with an end that can be attained; it is potentially 'open ended', that is, it opens up other areas of discovery, knowledge and skills, problems to be uncovered and resolved. It is a method which can be used in one subject area, and yet, it has great advantages in linking subject disciplines, particularly science, technology and mathematics with language arts.

Projects can be undertaken by individual students or by a group, a class or a school. The following examples involved a whole class and a school wide activity. The activity had to be managed and coordinated, the participants worked cooperatively and often collaboratively to achieve their goal.

► *An outcome oriented class activity*

In an extension to the farm activity described in Chapter 4, the technology teacher and the class teacher worked with all the children to produce a model farm animal. Some groups made the head; others the body; another the legs; and a fourth group concentrated on the udder and milk producing system. This kind of organization is familiar to art teachers working in the elementary classrooms or in an art workshop. The goal was to make a product. The students collaborated in making a life size animal from grocery boxes, card and paint. In this situation the time allocated was half a day and this task was the prime activity of the session.

► *A school wide project*

A more ambitious project was organized at the same school (Knobloch, Belch, The Technology Teacher V.54 No1 Sept 1994). The project was designed to involve everyone in the school from K-6 grade (900 students and their teachers). The time scale for the project was a whole term. The aim was to build a town with LEGO® bricks that had been donated to the school. The project was developed with the cooperation of the schools business partner, CH2 M Hill for the National Engineers week/TECHNO-EXPO. The availability of such a vast quantity of materials from LEGO Systems, Inc. is not something that can be replicated by other schools. It was a design opportunity that provided a challenge to the school. Similar projects may be developed using other available materials, for

example, discarded boxes, textile fabric, metal parts etc. plus any construction kits that are already available in the school. Nelson (1984) discusses the procedures involved in developing city building and community organization with students and teachers in California. Cardboard and paper were the main modeling materials used for these projects. Each school needs to plan their own resources for large scale activity.

The goal was to create a model town in the gymnasium towards the end of the spring term. How might such a large project be managed?

The management of the project three levels of action each integrated into the whole: project organization; procedure; process..

Process level:

The process may start at any point.

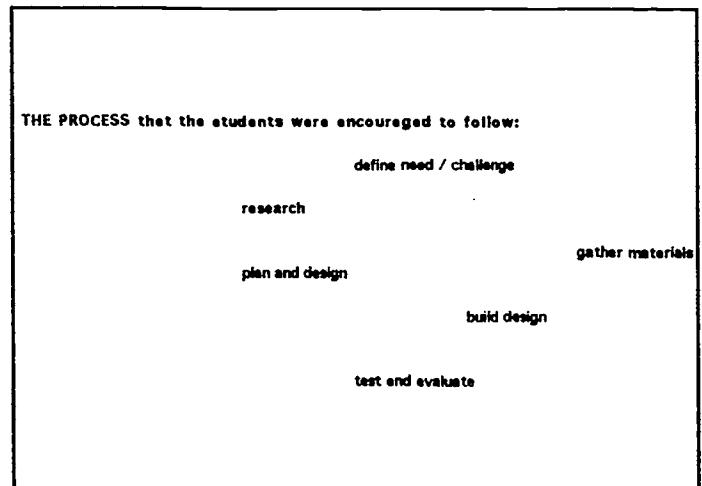

Procedure level:

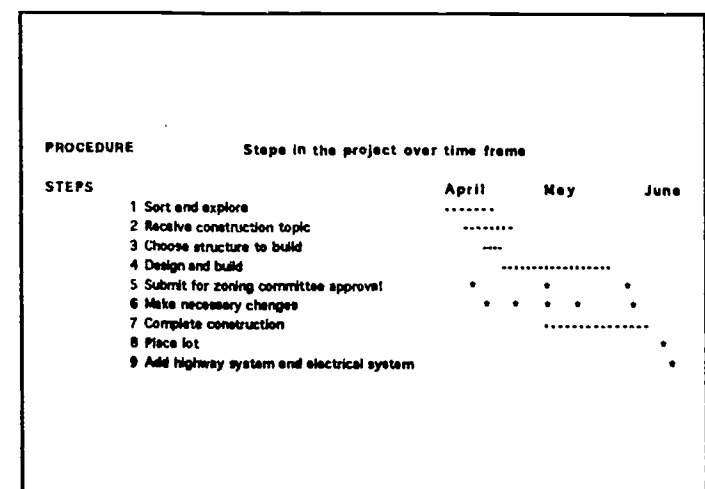

Project organization level:

THE PROJECT ORGANIZATION PLAN			
	GRADE LEVEL	ASPECT	PROGRAM OF STUDIES
ADMINISTRATORS	UNDERGRADUATE	Problems	Families and neighborhoods
TEACHERS	GRADE 1	Public safety	Social studies, health
	GRADE 2	Recreation	Composites
	GRADE 3	Community Manufacturing	Global communication, science
	GRADE 4	Communications	Math, Lang, arts, Science
	GRADE 5	Transportation	Science, Lang, arts, Math
SPONSORS	GRADE 6	Power	Science, Math, Social Studies

► **Team leadership is an ingredient of success in designing activity**

The key person in this instance was the technology specialist. Design projects need to have an identified coordinator, which may be a teacher or a student. This project was structured and the course of action well managed by a zoning committee of eleven, grade 3-6 students in cooperation with teachers and administrators. They met at 7.30 am to plan, manage and evaluate the progress of the project. It involved risk taking. No-one knew exactly what it would be like until the town was constructed and when the electronic systems was functioning. There were several classes in each grade year, which were responsible for an aspect of the town. Grades K-2 came up with the title, 'Technotown'. The class activities were sub-divided into groups or teams. Each class had a different approach to completing the task. The class activities were sub-divided into groups or teams. Some classes spent a block of time working on it while others organized an 'on going' activity in the corner of the room, which students could do intermittently.

The whole project corresponded to the design activity profile introduced in Chapters 1 and set out in 5. All the design criteria were met :

- a response to an identified or perceived need (to meet challenge);
- creating or modifying something which did not previously exist ;
- the communication of thought and action using models and codes;
- an intentional outcome;
- a coherent and structured course of action;
- taking place over time;
- manifested within a system of values (aesthetic, technical, social, cultural, ecological);
- the outcome was a compromise of the accumulative demands of the activity (there were limitations to working with the materials);
- the outcome was justified by the results.

An important outcome of this kind of project is gained from linking the arts with the sciences. Design educational activity draws from both.

► **Another approach**

A different approach to developing a large scale project is offered as a workshop package for elementary age students at the the National Building Museum in Washington D.C.⁵ The workshop is titled 'City by Design', the onus is on teachers to prepare students thoroughly beforehand and to follow the scheme of work back in school. A package of materials is sent to the school in advance of the field trip. This program works very well for students who are doing social studies in 2nd and 3rd grades. The rationale is to involve students in the process of decision making of city planning, urban development and environmental concerns to prepare them to become future citizens of cities. In the pre- project activities students are encouraged to look at local architecture, the way that the built environment is organized. The aim is to enable students to become more visually aware and sensitive to their surroundings.

The whole activity in the museum lasts only one and a half action packed hours. The principles of the design management are similar to the larger scale project just described.

The objectives include: simple map reading; identifying goods and services; listing planning zoning categories; designing a model building with simple materials; choosing a site and justifying the choice; demonstrating a basic understanding of the process and needs of a city. The procedure in the museum has 4 steps:

- Introduction to the project (whole class);**
- City Planning (in 4 groups);**
- Building (individual work within group);**
- Creating the city (whole group around floor plan).**

This is a very exciting experience for the students, their performance is largely dependent on their preparation and experience at basic manipulative skills. The students engage in a great deal of designerly thinking in the course of the activity. The greatest drawback was that there is a lack of time for reflection between the different stages.

► **The project topic**

The rationale for a project focused on the town, the city, the community is not new. The development between the life in the classroom and the community is embodied in the philosophy of John Dewey a century ago. He believed that the activity in school should reflect real life and that students should take an active role in their learning in activities which

⁵Other design education materials are available from the Museum. A design activities book *Why Design? Projects from the National Building Museum* (SLAFER 1995 in press)

are a part of life's experiences.⁶ The purpose of developing a design project is to build upon student's existing knowledge and understanding of their cultural surrounding and their interests. Social studies and language arts are both rich areas for developing ideas for projects. Any aspect of the curriculum which stimulates need, opportunities, problems and challenges will be appropriate for design activity. Other ideas for school wide projects are: organizing an event in school; developing the communication system in school; designing a playground area for students with special needs; developing ecological awareness in the community.

Time, space and resources

► **Time**

How much time should be spent on a project and when? Will other class activities be suspended because of the project activity?

What amount of time should be allocated to the tasks?

Should it take place on consecutive days or be a weekly event? These are the kind of questions about the time scale of design activity that teachers ask. Teachers have to decide for themselves what schedule is best for them and their school. Here are some points which may help in making decisions:

Design activity needs time for reflection. Time to think through alternative processes, time for research, time to assess what has taken place, time to make modifications and changes. An activity that is too rushed will leave little time for reflection. Young children lose momentum, and the intense excitement of the action is diminished if there is too long a gap between meetings. Mini- projects need a couple of hours, and longer projects may take several days. The time spent has to be justified by the total learning value which is likely to cover several subjects.

► **Space**

A major issue for practical areas of the curriculum is whether they should take place in the general classroom with the class teacher or in a designated area with a specialist teacher. There are advantages and disadvantages to both situations. Where there are specialist teachers it makes sense when they work with the class teacher so that the curricula is consistent. Some schools have pods, where groups of student, teachers and their assistants can work outside the class room area. These offer great advantages of space for practical ac-

tivity. The ability to work with other people, in pairs and groups is an essential part of developing capability in designing. Provision for group activity will need to be considered in organization.

How will the room be organized? Where will each group work? Where will the materials and equipment be store? How will semi finished work be stored? How will the groups of students be selected? Students have plenty of ideas of their own about how to organize their classroom and it helps to involve them in evaluating their own classroom situation.

► **Resources**

One important advantage of working with groups is that resources can be shared, particularly where expensive technical equipment is concerned. The equipment and materials for designing activity can be immensely varied so it is not possible to make a detailed analysis in a short space. Several observations can be made:

- ***equipment needs to be accessible and clearly labeled;***
- ***there needs to be a wide variety of materials, these should be accessible and well presented in containers so that students can make choices when they need to;***
- ***items of equipment that are potentially hazardous (saws, glue guns, paper trimmers etc.) will need to be kept in a safe place. Students will need to learn to use equipment and materials responsibly as they progress through the school. Students are capable of collecting, arranging and organizing their classroom resources and for keeping areas clean and organized. Student helpers can be invaluable to the teacher.***

⁶The Center for Understanding the Built Environment has two useful publications in this respect: *Walk Around the Block* (1992) a Built Environment Curriculum.



A model hospital was an outcome of group design activity (Grade 1)



An important outcome of this kind of project is gained from linking the arts with the sciences. Design educational activity draws from both.

REFERENCES

- ARCHER, B. (1978). *Design in General Education* London: Royal College of Art.
- ARCHER, B. (1984). *Systematic Method for Designers* in CROSS, N. (Ed)(1984). *Developments in Design Methodology*. Open University. London: Wiley.
- ARCHER, B.(1992). *The Nature of Research into Design and Technology Education*. Design Curriculum Matters Series. Loughborough University of Technology: Department of Design and Technology.
- ARCHER, B. and ROBERTS, P. (1992). 'Design and Technological Awareness in Education.' Design Occasional Paper No 1. Loughborough University of Technology: Department of Design and Technology.
- ASSESSMENT OF PERFORMANCE UNIT (1991). *The Assessment of Performance in Design and Technology* London, U.K.: School Examinations and Assessment Council.
- BAYNES, K. (1994). 'Designerly Play' Design Occasional Paper No 2. Loughborough University of Technology: Department of Design and Technology.
- BAYNES, K. (1992). 'Children Designing.' Learning Design: Occasional Paper No 1 Loughborough University of Technology: Department of Design and Technology.
- BELCH, H. (1994). 'Technotown: A LEGO® Experience'. *The Technology Teacher* V.54 No1. Sept. 1994.
- BOWER, T. G. R. (1977). *The Perceptual World of the Child*, London: Fontana/Open Books.
- BRUNER J. and HASTE, H. (1987). *Making Sense*. London: Methuen.
- CHAILLE, C. and BRITAIN, L. (1991). *The Young Child as Scientist. A constructivist approach to early childhood education*. New York: Harper Collins.
- CHITTENDEN, E. (1991). *Authentic Assessment, Evaluation, and Documentation of Student Performance* in PERRONE, V. Ed. (1991) *Expanding Student Assessment*. Alexandria, VA: ASCD.
- COSTA, A. Ed. (1991). *Developing Minds*. A resource book for teaching thinking. Vol 1 Alexandria, VA: Association for Supervision and Curriculum Development..
- COSTA, A.(1991). *The Search for Intelligent Life* in A. COSTA Ed (1991) *Developing Minds*. A resource book for teaching thinking. Alexandria, VA: Association for Supervision and Curriculum Development..
- CROSS, N. (1982). 'Designerly Ways of Knowing', *Design Studies* 3 (4), 221 - 227
- DE BONO, E (1991). *The CoRT Thinking Program* in A. COSTA Ed.(1991). *Developing Minds*. Programs for Teaching Thinking Vol 2. Alexandria, VA: Association for Supervision and Curriculum Development..
- DEWEY, J. (1938). *Experience and Education*. New York: Collier-Macmillan.
- DUNN, S. and LARSON, R. (1990). *Design Technology: Children's Engineering*. New York, Philadelphia and London: The Falmer Press.
- DRIVER, R. SQUIRE, A. RUSHWORTH, P. and WOOD-ROBINSON, V. (1994). *Making Sense of Secondary Science: research into children's ideas*. London and New York: Routledge.
- FLAVELL, J.H. (1963). *The Developmental Psychology of Jean Piaget*. New York: Van Nostrand.
- GARDNER, H. (1983). *Frames of Mind*. New York: Basic Books.
- GUSKEY, T.R. (1994). 'Making the Grade: What benefits students?' *Educational Leadership*. V 22. No 2 October 1994.
- HARLEN, W. (1993). *Teaching and Learning in Primary Science*. London: Paul Chapman.
- HARMON, M., MOKROS, J., DAWSON, G., HARTWIG, R., HENDERSON, L., LOWERY, L., & TAYLOR, Z. (1988). 'Comments on the Need for New Assessment Materials' NSF cited by Hein, page 106/7 in V. PERRONE Ed.(1991) *Expanding Student Assessment* Alexandria, VA: ASCD.
- HEIN, G. (1991). *Active Assessment for Active Science* in V. PERRONE ed.(1991). *Expanding Student Assessment*. Alexandria, VA: ASCD.
- HOWE, A.C. (1993). *Science in Early Childhood Education*. in *Handbook of Research on the Education of Young Children*. (Ed. Spodak, B.) New York: Macmillan.
- HUTCHINSON, J. and HUTCHINSON, P. (1991). 'Process-based Technology Education' *The Technology Teacher*. May/June 1991. International Technology Education Association.
- KAMII, C. and DE VRIES R.(1978). *Physical Knowledge in Pre-School Education: implications of Piaget's Theory*. New Jersey: Prentice Hall.
- KNOBLOCH, S. (1994). 'Technotown: A School-Wide Technology Project'. *The Technology Teacher* V.54 No1. Sept. 1994.
- LAYTON, D. (1993). *Technology's Challenge to Science Education*. Philadelphia and Buckingham: Open University Press.
- OPIE, I. (1994). *The People in the Playground*. Oxford: Oxford University Press.
- OSBORNE, R. and FREYBERG, P. (1985). *Learning in Science: The Implications of Children's Science*. Auckland, New Zealand: Heinemann.
- OUTTERSIDE, Y.(1993). 'The Emergence of Design Ability.' Loughborough: DATER 93 Ed. Js. Smith.

- PELLEGRINI, A. D. and BOYD, B. (1993). *The Role of Play in Early Childhood Development and Education: Issues in Definition and Function* in SPODEK, B. (ED) (1993). *Handbook of Research on the Education of Young Children*. New York: Macmillan.
- PERKINS, D.N. (1982). *Knowledge as Design*. New Jersey: Erlbaum Associates
- PERKINS, D.N. (1984). "Creativity by Design." *Educational Leadership*: Association of Supervision and Curriculum Development. 42(1) 18-25.
- PERRONE, V. Ed.(1991). *Expanding Student Assessment*. Alexandria, VA: Association for Supervision and Curriculum Development..
- MARZANO, J. R., PICKERING, D. & Mc TIGHE, J. (1993). *Assessing Student Outcomes*. Alexandria, VA: Association for Supervision and Curriculum Development..
- MC.CORMICK, R. (1993). *Design education and Science: Practical Implications* in M. DE VRIES, N.CROSS, and D. P. GRANT (1993). *Design Methodology and Relationships with Science*. Dorrecht/Boston/London: Kluwer Academic Publishers.
- MILLER, J. L. and SELLER, J. (1985). *Curriculum Perspectives and Practice*. New York: Longman.
- NATIONAL RESEARCH COUNCIL (Draft /Nov 1994.) *National Science Education Standards*. National Academy Press.
- NELSON, D. (1984). *Transformations: Process and Theory*. City Building Education. Santa Monica, California: Center for City Building Educational Programs.
- ROGERS, M. & CLARE, D. (1994). 'The Process Dairy: developing capability with national curriculum design and technology—some initial findings'. Loughborough: IDATER 94 Ed. J.S. Smith .
- RUBIN, F. FEIN, G., and VANDENBERG B.(1983). Play: in E.M. HETHERINGTON (Ed), *Handbook of Child Psychology: Socialization, personality and social development*, Vol. IV 693-774. New York: Wiley.
- SAVAGE, E. & STERRY, L. (1989). *A Conceptual Framework for Technology Education* International Technology Education Association.
- SCAIFE J & WELLINGTON, J.(1993) *Information Technology in Science and Technology Education*. Buckingham and Philadelphia: Open University Press.
- SCHON, D. and WIGGINS, G.(1992). 'Kinds of Seeing and Their Functions in Designing' *Design Studies* V 13 N2. April 1992.
- SECRETARY'S COMMISSION ON ACHIEVING NECESSARY SKILL (1991). 'What Work Requires of Schools'. A Scans Report for America 2000. Washington D.C. : United States Department of Labor.
- SEELEY, M. (1994). 'The Mismatch Between Assessment and Grading'. *Educational Leadership*. V 22. No 2 October 1994.
- SHEPHARD, L.A. (1989). 'Why We Need Better Assessment'. *Educational Leadership* 46, 7: 4-9. April 1989.
- SLAFER, A. (1995 in press) Why Design? Projects from the National Building Museum Chicago: Chicago Review Press.
- SPERLING, D. (1994). 'Assessment and Reporting : A Natural Pair'. *Educational Leadership*. V 22. No 2 October 1994.
- STENHOUSE, L. (1975). *An Introduction to Curriculum Research and Development*. London: Hienemann.
- TECHNOLOGY EDUCATION ADVISORY COUNCIL(1988). *Technology: A National Imperative*. A Report by the Technology Education Advisory Council. Reston, VA.: ITEA
- WIGGINS, G. (1989). 'Teaching to the (Authentic) Test.' *Educational Leadership* 46,7:41-47.
- WRIGHT, T. R. ISRAEL,E.N. & LAUDA, D. P. (1993). *A Decision Makers Guide to Technology Education*. International Technology Education Association.
- ZESSOULES, R. & GARDNER, H. (1991). *Beyond the Buzzword and into the Classroom* in PERRONE, V. Ed. (1991) *Expanding Student Assessment*. Alexandria, VA: ASCD.

About the Author

Pauline Ann Bottrill NDD. ATD.MA (RCA)

Pauline Bottrill directed the 'Designing and Learning in the Elementary School' project which was funded by The National Endowment for the Arts and the International Technology Education Association. She holds a postgraduate degree in design education from the Royal College of Art, London and has teaching experience with children from kindergarten to high school grades and with students at undergraduate and postgraduate levels.

Since emigrating to the United State with her family in 1990, Pauline became Research Associate with ITEA. She is a Fellow of the Royal Society of Arts (RSA); founder member of the Design and Technology Association (DATA); and member of the Association for Supervision and Curriculum Development (ASCD). Prior to leaving London, she was a Senior Lecturer in Education at Roehampton Institute (University of Surrey), London. As coordinator for the Design and Technology Teaching Studies Area at Roehampton she was involved in implementing the National Curriculum for Technology for England and Wales. She has presented papers at international conferences and maintains contact with international leaders in the field of design and technology education. Currently, she is engaged in a research study of the design activity of young children with Loughborough University of Technology, England.

International Technology Education Association

Kendall Starkweather Ph.D. Executive Director
Pauline Bottrill. Research Associate. Chair.
Judy Miller. Production
Karen Ulatowski. Meetings Secretary

Schools editorial representatives

Jeanne Bingham. Grade 5. Haycock Elementary School, VA.
Barbara Brown. Pre-School. Wesley Pre-School. Parent representative, VA.
Susan Cave. Science/Math/Technology. Sleepy Hollow Elementary School, VA.
Susan Doubles. Kindergarten. Dransville Elementary School, VA.
Gary Foveaux. Coordinator Industrial Technology Education, Fairfax County Public Schools, VA.
Klare Grigg. Reading. Stenwood Elementary School, VA.
Diane Harazin. Technology Specialist. Dranesville Elementary school, VA.
Cynthia F. Jgens. Grade 1. Stenwood Elementary School, VA.
Steve Knobloch. Technology Training specialist. Fairfax County Public schools.
Mary Lynne McKenzie. Grade 1. Stenwood Elementary School, VA.
Kent Schweitzer. Technology Education. Joyce Kilmer Intermediate School, VA.
Douglas Smith. LEGO Dacta® representative.

The Designing and Learning in the Elementary School project was funded by a grant from the National Endowment for the Art

USEFUL ADDRESSES

Association for Supervision
and Curriculum Development
1250 N. Pitt Street
Alexandria, VA 22314-1453
Tel: (703) 549-1453

AUTODESK, INC.
2320 Marinship Way
Sausalito, CA 94965
Tel: (415) 491-8277

Cooper-Hewitt
National Design Museum
Smithsonian Institution
2, East 91st Street
New York, NY 10128
Tel: (212) 860-6899

International Technology
Education Association
1914 Association Drive
Reston, VA 22091-1502
Tel: (703) 860-2100

• LEGO Dacta
555 Taylor Road, PO Box 1600
Enfield, CT 06083-1600
Tel: (800) 527-8339

Loughborough University of Technology:
Department of Design and Technology.
Loughborough, Leicestershire
LE113TU, England
Tel: (0509) 263171 Fax:(0509) 610813

Modern School Supplies Inc.
PO Box 958
Hartford, CT 06143
Tel: (800) 243-2329

Plastruct
1020 S Wallace Place
City of Industry,
California 9174
Tel: (818) 912-7016

American Institute of Architects
American Architectural Foundation
1735 New York Avenue, N.W.
Washington D.C. 20006-5292
Tel: (202) 626 7500

National Building Museum
Pension Building
Judiciary Square, N.W.
Washington, D.C. 20001
Tel: (202) 272-2448

International Technology Education Association
1914 Association Drive
Reston, VA 22091

BEST COPY AVAILABLE

59

ISBN 1-887101-00-1